

# Mini-spectrometers

Integrating a Hamamatsu image sensor, its driver circuit, and optical elements into a compact case



■ Thin type  
C13555MA



■ Ultra-compact spectrometer head  
C12666MA



■ For UV to near IR  
C10082MD

Архангельск (8182)63-90-72  
Астана (7172)727-132  
Астрахань (8512)99-46-04  
Барнаул (3852)73-04-60  
Белгород (4722)40-23-64  
Брянск (4832)59-03-52  
Владивосток (423)249-28-31  
Волгоград (844)278-03-48  
Вологда (8172)26-41-59  
Воронеж (473)204-51-73  
Екатеринбург (343)384-55-89  
Иваново (4932)77-34-06

Ижевск (3412)26-03-58  
Иркутск (395)279-98-46  
Казань (843)206-01-48  
Калининград (4012)72-03-81  
Калуга (4842)92-23-67  
Кемерово (3842)65-04-62  
Киров (8332)68-02-04  
Краснодар (861)203-40-90  
Красноярск (391)204-63-61  
Курск (4712)77-13-04  
Липецк (4742)52-20-81  
Киргизия (996)312-96-26-47

Магнитогорск (3519)55-03-13  
Москва (495)268-04-70  
Мурманск (8152)59-64-93  
Набережные Челны (8552)20-53-41  
Нижний Новгород (831)429-08-12  
Новокузнецк (3843)20-46-81  
Новосибирск (383)227-86-73  
Омск (3812)21-46-40  
Орел (4862)44-53-42  
Оренбург (3532)37-68-04  
Пенза (8412)22-31-16  
Казахстан (772)734-952-31

Пермь (342)205-81-47  
Ростов-на-Дону (863)308-18-15  
Рязань (4912)46-61-64  
Самара (846)206-03-16  
Санкт-Петербург (812)309-46-40  
Саратов (845)249-38-78  
Севастополь (8692)22-31-93  
Симферополь (3652)67-13-56  
Смоленск (4812)29-41-54  
Сочи (862)225-72-31  
Ставрополь (8652)20-65-13  
Таджикистан (992)427-82-92-69

Сургут (3462)77-98-35  
Тверь (4822)63-31-35  
Томск (3822)98-41-53  
Тула (4872)74-02-29  
Тюмень (3452)66-21-18  
Ульяновск (8422)24-23-59  
Уфа (347)229-48-12  
Хабаровск (4212)92-98-04  
Челябинск (351)202-03-61  
Череповец (8202)49-02-64  
Ярославль (4852)69-52-93

# Mini-spectrometers

Mini-spectrometers are compact spectrometers (polychromators) whose optical system, image sensor, and circuit are condensed into a small case.

Previous spectroscopic instruments used in the chemical analysis field and the like have been typically large and expensive. In contrast, mini-spectrometers are compact and portable, making it possible to take real-time measurements on-site, rather than having to bring in measurement samples into a room in which a spectroscopic instrument is installed.

This miniaturization also made it possible to incorporate them into various types of equipment. They are used in environmental measurement instruments, color measurement instruments, production lines, information devices and so on.

Hamamatsu provides more than 20 types of mini-spectrometers that cover the spectral range from UV to near infrared. Further, Hamamatsu offers ultra-compact types that allow them to be installed in mobile devices and collaborate with portable devices.



# Contents

- **MOEMS technology that underlies mini-spectrometers** . . . 3
- **Applications** . . . . . 4
- **Selection guide** . . . . . 5
- **TM series** . . . . . 7
  - For UV to near IR . . . . . 7
    - High sensitivity C10082CA, C10083CA
    - High resolution C10082CAH, C10083CAH
  - For UV to near IR . . . . . 9
    - Wide dynamic range C10082MD, C10083MD
  - For Visible to near IR . . . . . 11
    - High sensitivity C11697MB
- **TG series** . . . . . 13
  - For UV and for visible to near IR . . . . . 13
    - High sensitivity C9404CA, C9405CB
    - High resolution C9404CAH
  - For Raman spectroscopy . . . . . 15
    - High resolution C11713CA, C11714CB
  - For near IR . . . . . 17
    - C11482GA, C9913GC, C9914GB, G11118GA
- **TF series** . . . . . 19
  - Thin type . . . . . 19
    - High sensitivity C13555MA, C13053MA
    - For near IR C14486GA
    - High resolution C13054MA, C14214MA
- **RC series** . . . . . 22
  - Compact, low price type . . . . . 22
    - C11007MA, C11008MA, C11009MA, C11010MA
- **Micro-spectrometers, MS series** . . . . . 24
  - Ultra-compact spectrometer heads . . . . . 24
    - Wide dynamic range C12666MA
    - High sensitivity C12880MA
    - For near IR C11708MA
- **Technical note** . . . . . 26
  - 1. Structure . . . . . 26
  - 2. Characteristics . . . . . 27
  - 3. Operation mode . . . . . 31
  - 4. Evaluation software . . . . . 33
  - 5. Application examples . . . . . 36
- **Related products** . . . . . 38



# MOEMS technology that underlies mini-spectrometers

The mini-spectrometer is a product that integrates Hamamatsu's MOEMS (micro-opto-electro-mechanical-systems) technology, which combines optical technology including opto-semiconductor devices and optical systems and MEMS technology, with circuit and software. The detector serving as the core of the mini-spectrometer is a proven Hamamatsu image sensor in analysis and measurement fields. Since Hamamatsu develops its own grating, which performs spectroscopy, grating with various specifications (high resolution, wide spectral range, high diffraction in the ultraviolet region, etc.) can be mounted on its mini-spectrometers.

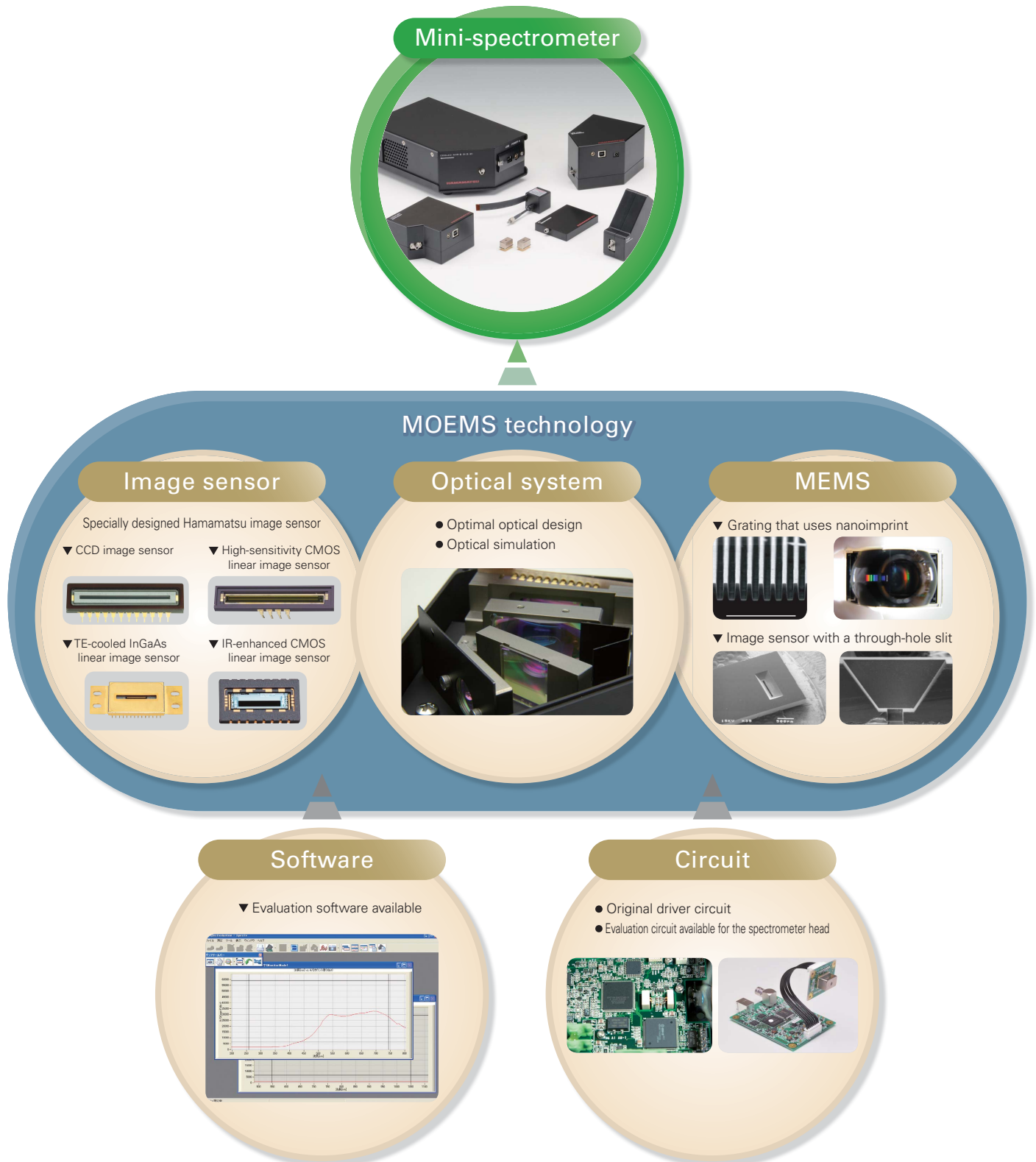



# Applications

## [ Color measurement (e.g., LED light source) ]

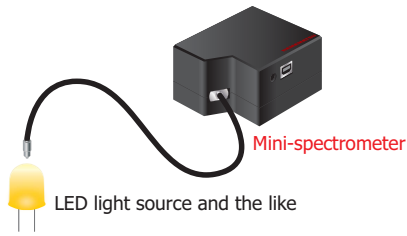

KACCC0796EA

A mini-spectrometer is used to perform spectral measurement and inspect LEDs or the like.

## [ Sugar content measurement ]

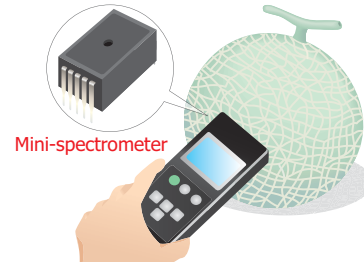

KACCC0797EA

Absorbance is used in applications such as handy brix meters, which measure sugar content.

## [ Display color measurement ]

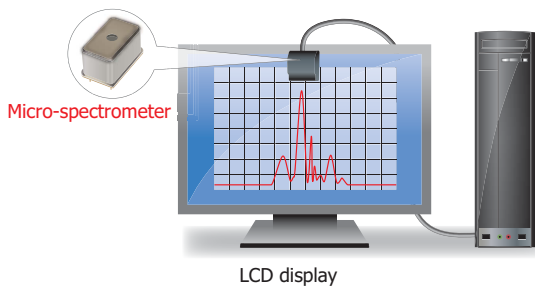

KACCC0599EB

The emission spectrum of LCDs is monitored with a micro-spectrometer.

## [ Film thickness measurement ]

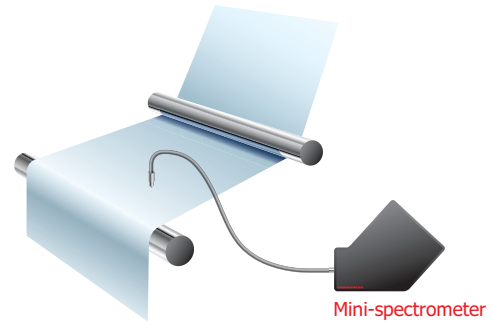

KACCC0600EB

White light interferometry is used to measure the spectrum peak count, film refractive index, and film thickness from the light incident angle.

## [ Plastic screening ]

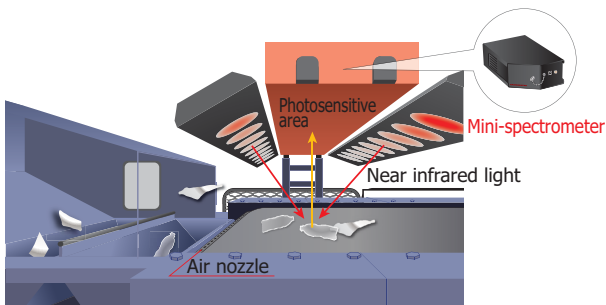

KACCC0601EB

Plastic screening is performed by using the fact that when near infrared light is directed at plastic, the wavelengths that are absorbed varies depending on the material.

## [ Fluorescence measurement ]

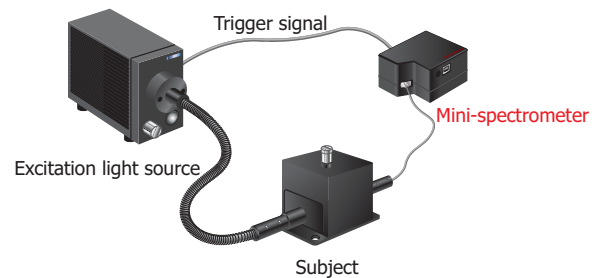

KACCC0602EB

Emission spectrum of fluorescent materials, such as fluorescent lamp and organic EL devices, is measured.

## [ Environmental analysis ]



KACCC0798EB

Mini-spectrometers are used in environmental analysis of water, soil, and the like.

## [ Color adjustment ]

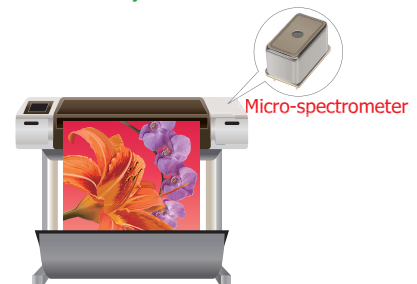

KACCC0803EA

Integrated into color printers and other printing equipment, micro-spectrometers monitor the color of printed materials.

# Selection guide

## Hamamatsu mini-spectrometers

Type	Type no.	Photo	Spectral response range (nm)														
			200	400	600	800	1000	1200	1400	1600	1800	2000	2200	2400	2600		
TM series	High sensitivity	C10082CA	①														
	High resolution	C10082CAH	①		200 to 800												
	Wide dynamic range	C10082MD	②														
	High sensitivity	C10083CA	①														
	High resolution	C10083CAH	①		320 to 1000												
	Wide dynamic range	C10083MD	②														
TG series	High sensitivity	C11697MB	②														
	High sensitivity	C9404CA	③		200 to 400												
	High resolution	C9404CAH	③														
TG series For Raman spectroscopy	High sensitivity	C9405CB	③			500 to 1100											
	High resolution	C11713CA	④	500 to 600													
TG series For near IR		C11714CB	④					790 to 920									
		C11482GA	⑤						900 to 1700								
	Cooled type	C9913GC	⑥														
		C9914GB	⑥									1100 to 2200					
TF series		C11118GA	⑥										900 to 2550				
	High sensitivity	C13555MA	⑦		340 to 830												
	For near IR	C13053MA	⑦			500 to 1100											
TF series For Raman spectroscopy		C14486GA	⑦					950 to 1700									
	High resolution	C13054MA	⑧					790 to 920									
RC series Spectrometer module		C14214MA	⑨					790 to 1050									
		C11007MA	⑩		340 to 780												
RC series Spectrometer head		C11008MA	⑩			640 to 1050											
		C11009MA	⑪		340 to 780												
Micro-spectrometer Spectrometer head		C11010MA	⑫			640 to 1050											
	Wide dynamic range	C12666MA	⑬		340 to 780												
MS series Spectrometer head	High sensitivity	C12880MA	⑬		340 to 850												
	For near IR	C11708MA	⑭			640 to 1050											

## Mini-spectrometers

### Line up



Spectral resolution max. (nm)	Integration time	Driving external power supply	Trigger*1 compatible	Internal image sensor		Type no.	See page
				Type	Pixels		
6 1 (typ.)	10 ms to 10000 ms	+5 V	○	Back-thinned CCD image sensor	2048	C10082CA	7
						C10082CAH	
6	5 ms to 10000 ms	Not needed (USB bus power only)	○	CMOS linear image sensor	1024	C10082MD	9
8 (λ=320 to 900 nm) 1 (typ.) (λ=320 to 900 nm)	10 ms to 10000 ms	+5 V	○	Back-thinned CCD image sensor	2048	C10083CA	7
						C10083CAH	
8	5 ms to 10000 ms	Not needed (USB bus power only)	○	CMOS linear image sensor	1024	C10083MD	9
8	30 μs to 100000 μs	Not needed (USB bus power only)	◎	High-sensitivity CMOS linear image sensor	2048	C11697MB	11
3 1 (typ.)	10 ms to 10000 ms	+5 V	○	Back-thinned CCD image sensor	1024	C9404CA	13
						C9404CAH	
5 (λ=550 to 900 nm)	10 ms to 10000 ms	+5 V	○	IR-enhanced back-thinned CCD image sensor	1024	C9405CB	
0.3 (typ.)	10 ms to 10000 ms	+5 V	○	Back-thinned CCD image sensor	2048	C11713CA	15
0.3 (typ.)	10 ms to 10000 ms	+5 V	○	IR-enhanced back-thinned CCD image sensor	1024	C11714CB	
7	6 μs to 10000 ms	Not needed (USB bus power only)	◎	InGaAs linear image sensor	512	C11482GA	17
7	5 ms to 10000 ms	+5 V, +12 V	-	InGaAs linear image sensor	512	C9913GC	
8	5 ms to 1000 ms	+5 V, +12 V	-	InGaAs linear image sensor	256	C9914GB	
20	6 μs to 40000 μs	+5 V, +12 V	◎	InGaAs linear image sensor	256	C11118GA	
3	11 μs to 100000 μs	Not needed (USB bus power only)	◎	High-sensitivity CMOS linear image sensor	512	C13555MA	19
3.5	11 μs to 100000 μs	Not needed (USB bus power only)	◎	High-sensitivity CMOS linear image sensor	512	C13053MA	
5 (typ.)	1 μs to 100000 μs	Not needed (USB bus power only)	◎	InGaAs linear image sensor	256	C14486GA	
0.4 (typ.)	11 μs to 100000 μs	Not needed (USB bus power only)	◎	High-sensitivity CMOS linear image sensor	512	C13054MA	
0.6	11 μs to 100000 μs	Not needed (USB bus power only)	◎	High-sensitivity CMOS linear image sensor	2048	C14214MA	
9	5 ms to 10000 ms	Not needed (USB bus power only)	-	CMOS linear image sensor	256	C11007MA	22
8	5 ms to 10000 ms	Not needed (USB bus power only)	-	IR-enhanced CMOS linear image sensor	256	C11008MA	
9	-	-	-	CMOS linear image sensor	256	C11009MA	
8	-	-	-	IR-enhanced CMOS linear image sensor	256	C11010MA	
15	-	-	-	CMOS linear image sensor	256	C12666MA	24
15	-	-	◎*2	High-sensitivity CMOS linear image sensor	288	C12880MA	
20	-	-	-	CMOS linear image sensor	256	C11708MA	

\*1: ○ External trigger (asynchronous) ◎ External trigger (Synchronous. Refer to P31) \*2: When used with C13016



# TM series

## For UV to near IR

**High sensitivity** C10082CA, C10083CA

**High resolution** C10082CAH, C10083CAH

These mini-spectrometers are a high-sensitivity type employing a back-thinned CCD image sensor as a detector. When compared with the type with a built-in CMOS linear image sensor, the sensitivity is higher by about two orders of magnitude. It is suitable for measurement in the weak light region such as in fluorescence measurement. The C10082CAH and C10083CAH are high resolution type achieving a spectral resolution of 1 nm.

## Spectral response (TM/TG/TF series)

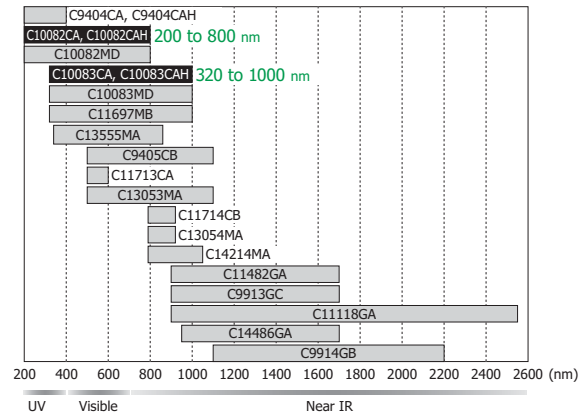

KACCB0161EF



Built-in CCD image sensor

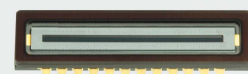

S10420-1106-01

### Features

- Employs back-thinned CCD image sensor: Sensitivity improved by two orders of magnitude compared to built-in CMOS type
- High resolution: 1 nm (C10082CAH, C10083CAH)
- Spectral resolution can be varied by selecting the slit width and NA.
- High throughput using quartz transmission grating
- Installable in equipment
- Stores wavelength conversion factor\*<sup>1</sup> in internal memory
- External trigger compatible\*<sup>2</sup>

### Applications

- Fluorescence measurement and other low-light-level measurement
- Semiconductor process control
- Characteristic evaluation of light sources (e.g., LED)



## Specifications (Ta=25 °C)

Parameter	C10082CA	C10082CAH	C10083CA	C10083CAH	Unit
Type	High sensitivity	High resolution	High sensitivity	High resolution	-
Spectral response range	200 to 800		320 to 1000		nm
Spectral resolution (FWHM)*3	6 max.	1 typ.	8*4 max.	1*4 typ.	nm
Wavelength reproducibility*5	-0.2 to +0.2				nm
Wavelength temperature dependence	-0.04 to +0.04				nm/°C
Spectral stray light*3 *6	-33 max.		-30 max.		dB
A/D conversion	16				bit
Integration time	10 to 10000				ms
Interface	USB 1.1				-
USB bus power current consumption	100 max.				mA
Driving external power supply	5				V
Dimensions (W × D × H)	95 × 92 × 76				mm
Weight	685				g
Image sensor	Back-thinned CCD image sensor (S10420-1106-01)				-
Number of pixels	2048				pixels
Slit*7 (H × V)	70 × 800	10 × 1000	70 × 800	10 × 1000	μm
NA*8	0.22	0.11	0.22	0.11	-
Connector for optical fiber	SMA905D				-
Operating temperature*9	+5 to +40				°C
Storage temperature*9	-20 to +70				°C
Trigger compatible*2	External trigger				-

## Output comparison (comparison with the CMOS type)

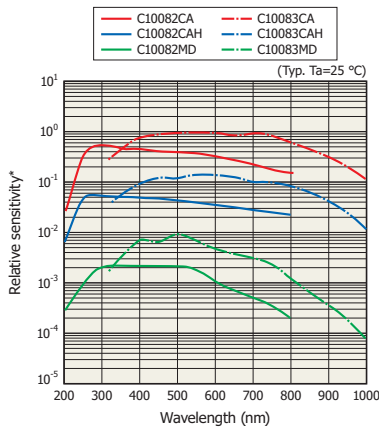

\* A/D count when constant light level enters optical fiber  
(Fiber core diameter: 600 μm,  
assuming no attenuation in optical fiber)

KACCB0168EC

## Spectral resolution

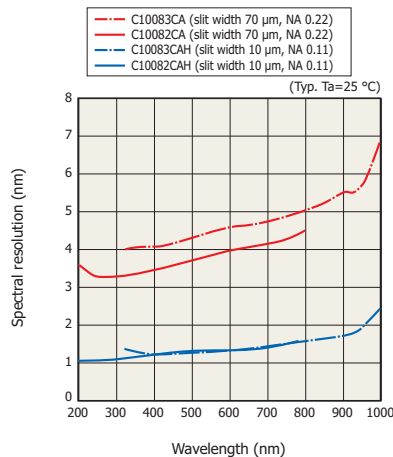

KACCB0169EC

## Dimensional outline (unit: mm)

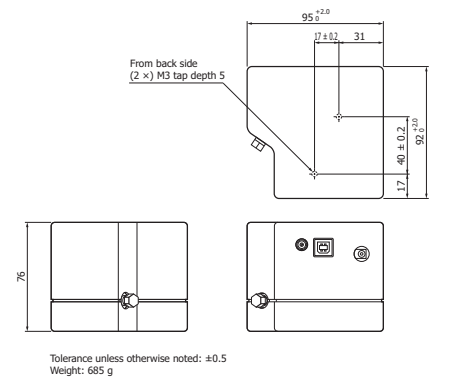

KACCA0188EG

\*1: A factor for converting the pixel numbers of the image sensor to wavelengths. A calculation factor for converting the A/D converted count into a value proportional to the input light level is not provided.

\*2: External trigger coaxial cable is sold separately. For details on the trigger function, see P.31.

\*3: When the slit in the table is used. The spectral resolution depends on the slit.

\*4: λ=320 to 900 nm

\*5: Measured under constant light input and other conditions

\*6: The ratio of the count measured when the following wavelength is input to the count measured when that wavelength ±40 nm is input  
C10082CA, C10082CAH: 500 nm, C10083CA, C10083CAH: 650 nm

\*7: Input slit aperture size

\*8: Numeric aperture (solid angle)

\*9: No dew condensation

Note: On the C10082CA/C10083CA series, the spectral resolution can be varied by selecting the NA and slit width. For the product lineup, see P.28.

# For UV to near IR

Wide dynamic range C10082MD, C10083MD

The C10082MD and C10083MD are a high-sensitivity type employing a CMOS linear image sensor as a detector. It is suitable for spectroscopic measurement when the light level is relatively high such as in absorbance measurement or light source spectrum evaluation.

## Spectral response (TM/TG/TF series)

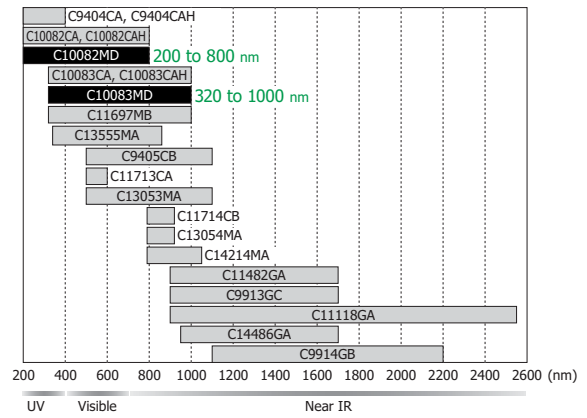

KACCB0162EF



### Features

- Wide dynamic range
- High throughput using quartz transmission grating
- External power supply not necessary: Uses USB bus power
- Installable in equipment
- Stores wavelength conversion factor\*1 in internal memory
- External trigger compatible\*2

### Applications

- Characteristic evaluation of light sources (e.g., LED)
- Transmittance and absorbance measurement of solutions and solid samples
- Sunlight and illumination light analysis

## Specifications (Ta=25 °C)

Parameter	C10082MD	C10083MD	Unit
Type	Wide dynamic range		-
Spectral response range	200 to 800	320 to 1000	nm
Spectral resolution (FWHM)* <sup>3</sup>	6 max.	8 max.	nm
Wavelength reproducibility* <sup>4</sup>	-0.2 to +0.2		nm
Wavelength temperature dependence	-0.04 to +0.04		nm/°C
Spectral stray light* <sup>3</sup> * <sup>5</sup>	-35 max.	-33 max.	dB
A/D conversion	16		bit
Integration time	5 to 10000		ms
Interface	USB 1.1		-
USB bus power current consumption	100 max.		mA
Driving external power supply	Not needed		-
Dimensions (W × D × H)	94 × 90 × 55		mm
Weight	470		g
Image sensor	CMOS linear image sensor (S8378-1024Q)		-
Number of pixels	1024		pixels
Slit* <sup>6</sup> (H × V)	70 × 800		μm
NA* <sup>7</sup>	0.22		-
Connector for optical fiber	SMA905D		-
Operating temperature* <sup>8</sup>	+5 to +40		°C
Storage temperature* <sup>8</sup>	-20 to +70		°C
Trigger compatible* <sup>2</sup>	External trigger		-

## Measurable optical fiber incident light level

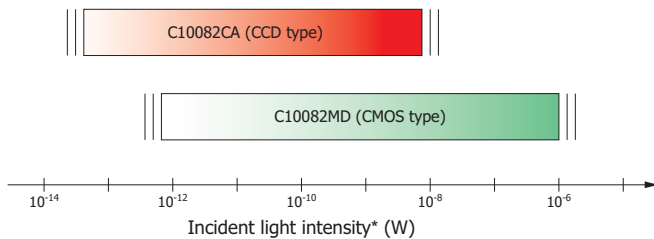

\* Fiber core diameter: 600 μm  
assuming no attenuation in optical fiber

KACCB0146EC

## Dimensional outline (unit: mm)

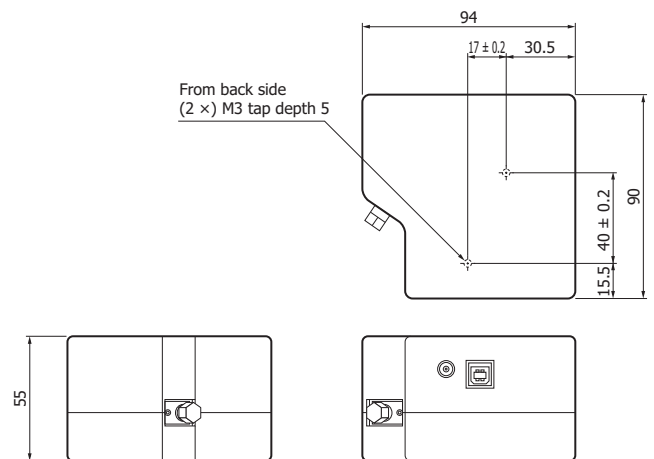

Tolerance unless otherwise noted: ±0.5  
Weight: 470 g

KACCA0171EE

- \*1: A factor for converting the pixel numbers of the image sensor to wavelengths. A calculation factor for converting the A/D converted count into a value proportional to the input light level is not provided.
- \*2: External trigger coaxial cable is sold separately. For details on the trigger function, see P.31.
- \*3: When the slit in the table is used. The spectral resolution depends on the slit.
- \*4: Measured under constant light input and other conditions
- \*5: The ratio of the count measured when the following wavelength light is input to the count measured when that wavelength ±40 nm light is input  
C10082MD: 500 nm, C10083MD: 650 nm
- \*6: Input slit aperture size
- \*7: Numeric aperture (solid angle)
- \*8: No dew condensation

# For visible to near IR

**High sensitivity** C11697MB

This mini-spectrometer is based on the C10083MD optical system platform with a newly developed high-sensitivity CMOS linear image sensor. The additional trigger function that can be used for short-term integration enables spectroscopic measurement of pulse emissions. Readout time has been significantly reduced, making it suitable for LED inspection and the like in industrial lines.

## Spectral response (TM/TG/TF series)

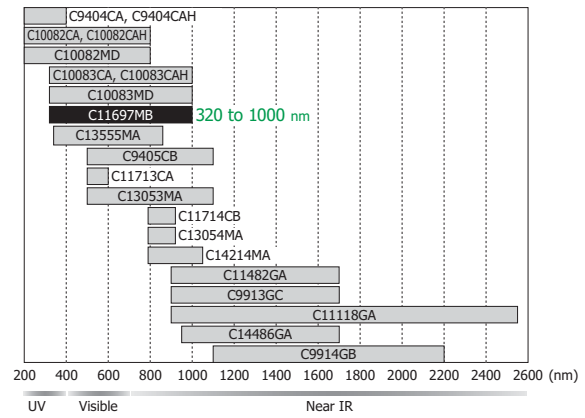

KACCB0227ED



### Features

- Trigger compatible (software trigger, external trigger)\*1
- High-speed readout (approx. 2 ms)
- Simultaneous charge integration charge
- High sensitivity: two orders of magnitude improvement (compared to the C10083MD)
- Stores wavelength conversion factor\*2 in internal memory
- External power supply not necessary: Uses USB bus power
- High throughput using quartz transmission grating
- Installable in equipment

### Applications

- Quality verification in LED inspection lines
- Pulse emission measurement



## Specifications (Ta=25 °C)

Parameter	C11697MB	Unit
Type	High sensitivity	-
Spectral response range	320 to 1000	nm
Spectral resolution (FWHM)*3	8 max.	nm
Wavelength reproducibility*4	-0.2 to +0.2	nm
Wavelength temperature dependence	-0.04 to +0.04	nm/°C
Spectral stray light*3 *5	-33 max.	dB
A/D conversion	16	bit
Integration time	30 to 100000	μs
Interface	USB 2.0	-
USB bus power current consumption	250 max.	mA
Driving external power supply	Not needed	-
Dimensions (W × D × H)	94 × 90 × 55	mm
Weight	470	g
Image sensor	High-sensitivity CMOS linear image sensor (S11639)	-
Number of pixels	2048	pixels
Slit*6 (H × V)	70 × 800	μm
NA*7	0.22	-
Connector for optical fiber	SMA905D	-
Operating temperature*8	+5 to +40	°C
Storage temperature*8	-20 to +70	°C
Trigger compatible*1	Software trigger External trigger	-

## Trigger function example

Sensor operation (integration) starts on a trigger signal, and then the digital data is acquired.

### [ Synchronous data measurement at external trigger input ]

Sensor operation (integration) starts when an external trigger edge (rising or falling edge can be specified) is applied to the external trigger terminal, and then the digital data is acquired.

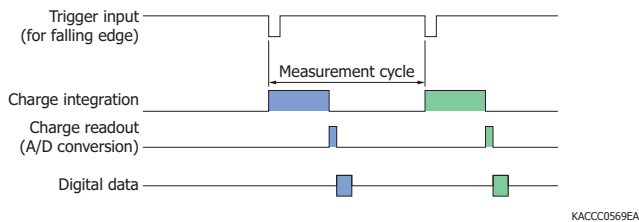

## Dimensional outline (unit: mm)

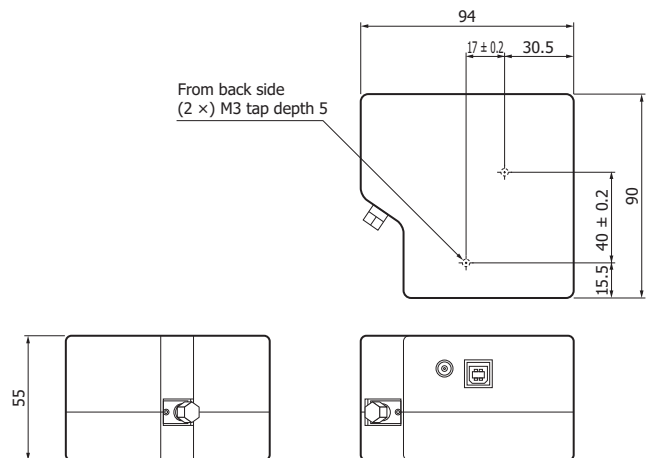

Tolerance unless otherwise noted: ±0.5  
Weight: 470 g

KACCA0171EE

\*1: External trigger coaxial cable is sold separately. For details on the trigger function, see P.31.

\*2: A factor for converting the pixel numbers of the image sensor to wavelengths. A calculation factor for converting the A/D converted count into a value proportional to the input light level is not provided.

\*3: When the slit in the table is used. The spectral resolution depends on the slit.

\*4: Measured under constant light input and other conditions

\*5: The ratio of the count measured when a 650 nm light is input to the count measured when that wavelength ± 40nm light is input.

\*6: Input slit aperture size

\*7: Numeric aperture (solid angle)

\*8: No dew condensation

# TG series

## For UV and for visible to near IR

**High sensitivity** C9404CA, C9405CB

**High resolution** C9404CAH

These mini-spectrometers are a high-sensitivity type employing a back-thinned CCD image sensor as a detector. The C9404CA and C9404CAH are exclusively designed for UV applications (spectral response range 200 to 400 nm). The C9405CB has a built-in IR-enhanced CCD image sensor, and its spectral response range is 500 to 1100 nm.

## Spectral response (TM/TG/TF series)

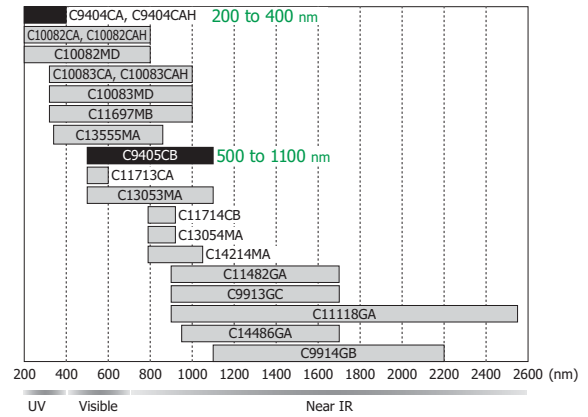

KACCB0163EF



### Features

- Employs back-thinned CCD image sensor
- High near infrared sensitivity (C9405CB)
- High resolution: 1 nm (C9404CAH)
- High throughput using quartz transmission grating
- Stores wavelength conversion factor\*1 in internal memory
- External trigger compatible\*2
- Installable in equipment

### Applications

- [ C9404CA, C9404CAH ]
  - Fluorescence measurement and other low-light-level measurement
  - UV light source spectrum evaluation
- [ C9405CB ]
  - Sugar content and acidity detection of foods
  - Film thickness gauge

## Specifications (Ta=25 °C)

Parameter	C9404CA	C9404CAH	C9405CB	Unit
Type	High sensitivity	High resolution	High sensitivity	-
Spectral response range	200 to 400		500 to 1100	nm
Spectral resolution (FWHM)*3	3 max.	1 typ.	5 max. (550 to 900 nm)	nm
Wavelength reproducibility*4	-0.1 to +0.1		-0.2 to +0.2	nm
Wavelength temperature dependence	-0.02 to +0.02			nm/°C
Spectral stray light*3 *5	-35 max.			dB
A/D conversion	16			bit
Integration time	10 to 10000			ms
Interface	USB 1.1			-
USB bus power current consumption	150 max.			mA
Driving external power supply	5			V
Dimensions (W × D × H)	125.7 × 115.7 × 75			mm
Weight	670			g
Image sensor	Back-thinned CCD image sensor (S10420-1006-01)		IR-enhanced back-thinned CCD image sensor (S11510-1006)	-
Number of pixels	1024			pixels
Slit*6 (H × V)	140 × 500	10 × 1000	70 × 800	μm
NA*7	0.11		0.22	-
Connector for optical fiber	SMA905D			-
Operating temperature*8	+5 to +40			°C
Storage temperature*8	-20 to +70			°C
Trigger compatible*2	External trigger			-

## Output comparison

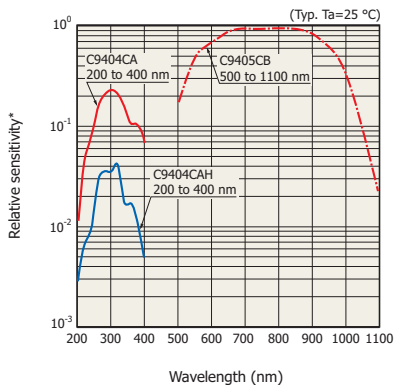

\* A/D count when constant light level enters optical fiber  
(Fiber core diameter: 600 μm, assuming no attenuation in optical fiber)

KACC80292EA

## Spectral resolution

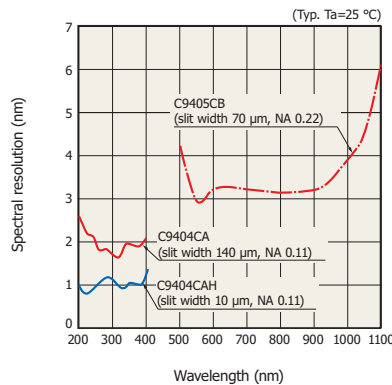

KACC80291EA

## Dimensional outline (unit: mm)

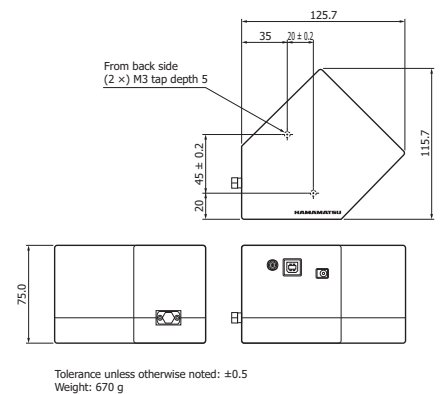

KACCA0202ED

\*1: A factor for converting the pixel numbers of the image sensor to wavelengths. A calculation factor for converting the A/D converted count into a value proportional to the input light level is not provided.

\*2: External trigger coaxial cable is sold separately. For details on the trigger function, see P.31.

\*3: When the slit in the table is used. The spectral resolution depends on the slit.

\*4: Measured under constant light input and other conditions

\*5: The ratio of the count measured when the following wavelength light is input to the count measured when that wavelength ±20 nm (C9404CA, C9404CAH) or ±40 nm (C9405CB) light is input  
C9404CA/C9404CAH: 300 nm, C9405CB: 800 nm

\*6: Input slit aperture size

\*7: Numeric aperture (solid angle)

\*8: No dew condensation

Note: As the C9405CB is characterized by  $\frac{\text{Upper limit of spectral response range}}{\text{Lower limit of spectral response range}} > 2$  due to its structure, high-order light is emitted. To eliminate this light, use it in combination with a long-pass filter if necessary.

# For Raman spectroscopy

High resolution C11713CA, C11714CB

These mini-spectrometers are a high resolution type suitable for Raman spectroscopy.

The spectral response range of the C11713CA and C11714CB is 500 to 600 nm and 790 to 920 nm, respectively. Their spectral resolution is 0.3 nm.

## Spectral response (TM/TG/TF series)

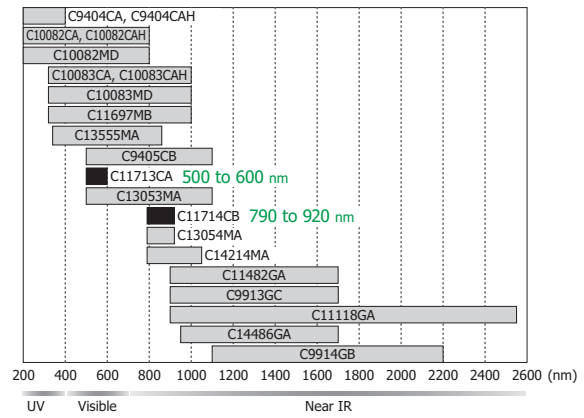

KACCB0228ED



### Features

- High resolution: 0.3 nm typ.
- Compact size: Installable in equipment
- High throughput using quartz transmission grating
- Employs back-thinned CCD image sensor with improved etaloning characteristics
- Stores wavelength conversion factor\*1 in internal memory
- External trigger compatible\*2

### Applications

- Raman spectroscopy



## Specifications (Ta=25 °C)

Parameter	C11713CA	C11714CB	Unit
Type	For Raman spectroscopy <b>High resolution</b>		-
Spectral response range	500 to 600	790 to 920	nm
Spectral resolution (FWHM)*3	0.3 typ., 0.5 max.		nm
Wavelength reproducibility*4	-0.1 to +0.1		nm
Wavelength temperature dependence	-0.04 to +0.04		nm/°C
Spectral stray light*3 *5	-30 max.		dB
A/D conversion	16		bit
Integration time	10 to 10000		ms
Interface	USB 1.1		-
USB bus power current consumption	150 max.		mA
Driving external power supply	5		V
Dimensions (W × D × H)	120 × 70 × 60		mm
Weight	592		g
Image sensor	Back-thinned CCD image sensor (S10420-1106-01)	IR-enhanced back-thinned CCD image sensor (S11510-1006)	-
Number of pixels	2048	1024	pixels
Slit*6 (H × V)	10 × 1000		μm
NA*7	0.11		-
Connector for optical fiber	SMA905D		-
Operating temperature*8	+5 to +40		°C
Storage temperature*8	-20 to +70		°C
Trigger compatible*2	External trigger		-

## Spectral resolution vs. wavelength

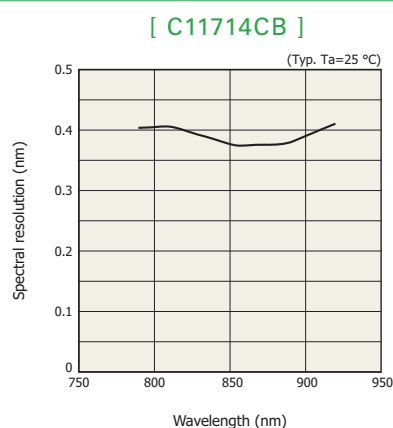
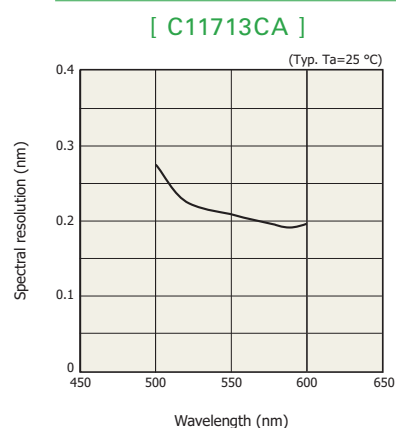

## Dimensional outline (unit: mm)

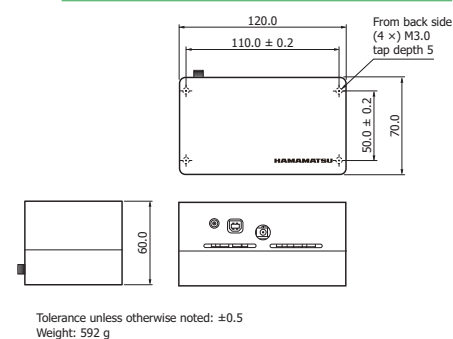

\*1: A factor for converting the pixel numbers of the image sensor to wavelengths. A calculation factor for converting the A/D converted count into a value proportional to the input light level is not provided.

\*2: External trigger coaxial cable is sold separately. For details on the trigger function, see P.31.

\*3: When the slit in the table is used. The spectral resolution depends on the slit.

\*4: Measured under constant light input and other conditions

\*5: The ratio of the count measured when the following wavelength light is input to the count measured when that wavelength ±10 nm light is input  
C11713CA: 550 nm, C11714CA: 860 nm

\*6: Input slit aperture size

\*7: Numeric aperture (solid angle)

\*8: No dew condensation

## For near IR

C11482GA, C9913GC

C9914GB, C11118GA

Near infrared light detection mini-spectrometers employing InGaAs linear image sensor. The three available spectral response ranges are 0.9 to 1.7  $\mu\text{m}$ , 1.1 to 2.2  $\mu\text{m}$ , 0.9 to 2.55  $\mu\text{m}$ . Low-noise, TE-cooled types are also available.

## Spectral response (TM/TG/TF series)

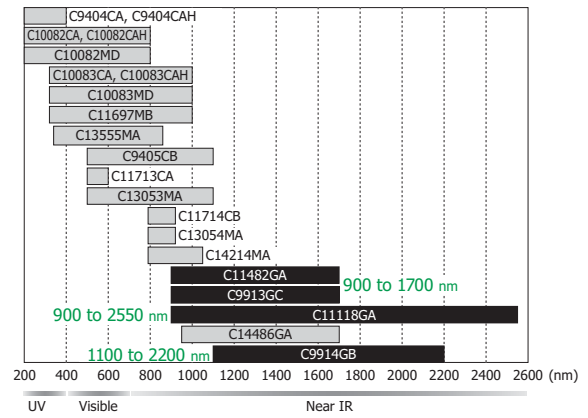

KACCB0165EF



### Features

- Low noise (cooled type: C9913GC, C9914GB, C11118GA)
- External power supply not necessary, USB bus powered\*1 (C11482GA)
- High throughput using quartz transmission grating
- Installable in equipment
- Stores wavelength conversion factor\*2 in internal memory
- Trigger compatible (software trigger, external trigger): C11482GA, C11118GA

### Applications

#### [ C11482GA ]

- Moisture measurement
- Evaluation of optical communication components
- Film thickness measurement



#### [ C9913GC, C9914GB ]

- Moisture measurement
- Composition analysis in the foods and agricultural sectors
- Chemical product process control
- Plastic sorting

#### [ C11118GA ]

- CH group absorption (2.3  $\mu\text{m}$  band) measurement
- Soil analysis, component analysis
- Plastic sorting

Specifications (Ta=25 °C)

Parameter	C11482GA	C9913GC	C9914GB	C11118GA	Unit
Photo					-
Type	For near IR	For near IR	For near IR Cooled type		-
Spectral response range	900 to 1700	900 to 1700	1100 to 2200	900 to 2550	nm
Spectral resolution (FWHM)*3	7 max.	7 max.	8 max.	20 max.	nm
Wavelength reproducibility*4	-0.2 to +0.2	-0.2 to +0.2	-0.4 to +0.4	-0.8 to +0.8	nm
Wavelength temperature dependence	-0.04 to +0.04	-0.02 to +0.02	-0.04 to +0.04	-0.08 to +0.08	nm/°C
Spectral stray light*3	-33 max.*5	-35 max.*5		-30 max.*6	dB
A/D conversion	16				bit
Integration time*7 *8	6 μs to 10000 ms	5 ms to 10000 ms	5 ms to 1000 ms	6 μs to 40000 μs	-
Interface	USB 2.0	USB 1.1		USB 2.0	-
USB bus power current consumption	350 max.	250 max.			mA
Driving external power supply	Power supply for cooling element*9	5/1.8 max.	5/2.8 max.	5/2.8 max.	V/A
	Power supply for cooling fan*9	12/0.2 max.			V/A
Dimensions (W × D × H)	38.5 × 106 × 86	142 × 218 × 82			mm
Weight	280	1700			g
Image sensor	InGaAs linear image sensor (G9204-512D)	TE-cooled type InGaAs linear image sensor (G9204-512S)	TE-cooled type InGaAs linear image sensor	TE-cooled type InGaAs linear image sensor (G9208-256W)	-
Number of pixels	512*10	512*10	256*10	256*11	pixels
Slit*12 (H × V)	70 × 500	70 × 500		140 × 500	μm
NA*13	0.22				-
Connector for optical fiber	SMA905D				-
Operating temperature*14	+5 to +40	+5 to +35 (+5 to +30*15)			°C
Storage temperature*14	-20 to +70	-20 to +70			°C
Trigger compatible*16	Software trigger External trigger	-	-	Software trigger External trigger	-

Spectral response of InGaAs linear image sensors

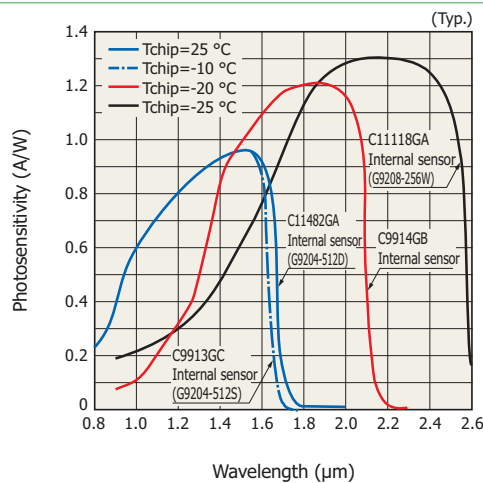

KMIR80093EB

Dimensional outlines (unit: mm)

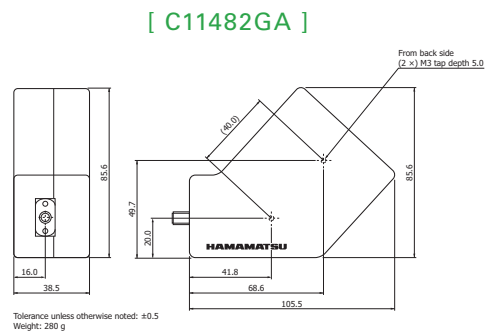

KACCA0146EE

[ C9913GC, C9914GB, G11118GA ]

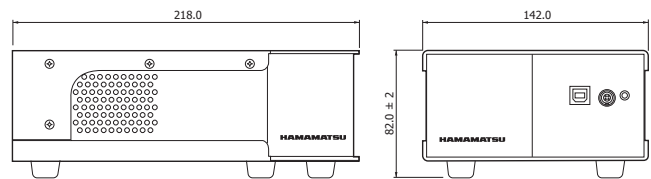

Tolerance unless otherwise noted: ±1.0  
Weight: 1.7 kg

KACCA0368EA

\*1: C9913GC, C9914GB, C11118GA: 5 V and 12 V power supplies required  
 \*2: A conversion factor for converting image sensor pixel numbers into wavelengths. A calculation factor for converting the A/D converted count into a value proportional to the input light level is not provided. \*3: When the slit in the table is used. The spectral resolution depends on the slit.  
 \*4: Measured under constant light input and other conditions \*5: The ratio of the count measured when the following wavelength light is input to the count measured when that wavelength ±40 nm light is input, C11482GA/C9913GC: 1300 nm, C9914GB: 1650 nm \*6: The ratio of the count measured when a 1700 nm light is input to the count measured when that wavelength ±80 nm light is input \*7: Depends on the image sensor dark current \*8: Excludes defect pixels \*9: Maximum value under steady-state condition. Note that inrush current flows at startup. Connector for external power supply included (C9913GC, C9914GB, C11118GA) \*10: No defect pixels (when set to low gain). Defect pixels are pixels that are outside the specifications of the image sensor's electrical and optical characteristics. \*11: Up to three non-consecutive defect pixels may be present (when set to low gain). Defect pixels are pixels that are outside the specifications of the image sensor's electrical and optical characteristics. \*12: Input slit aperture size \*13: Numeric aperture (solid angle) \*14: No dew condensation \*15: Operating temperature in which cooling control is possible \*16: External trigger coaxial cable is sold separately. For details on the trigger function, see P.31.

# TF series

## Thin type

**High sensitivity** C13555MA, C13053MA

**For near IR** C14486GA

**High resolution** C13054MA, C14214MA

These mini-spectrometers are a thin type that has achieved 12 mm thickness while maintaining high performance. The incorporation of a high-sensitivity CMOS image sensor has achieved high sensitivity equivalent to that of a CCD and low power consumption. Moreover, the trigger function that can be used for short-term integration enables spectroscopic measurement of pulse emissions. The C13054MA is a high resolution mini-spectrometer suitable for Raman spectroscopy.

## Spectral response (TM/TG/TF series)

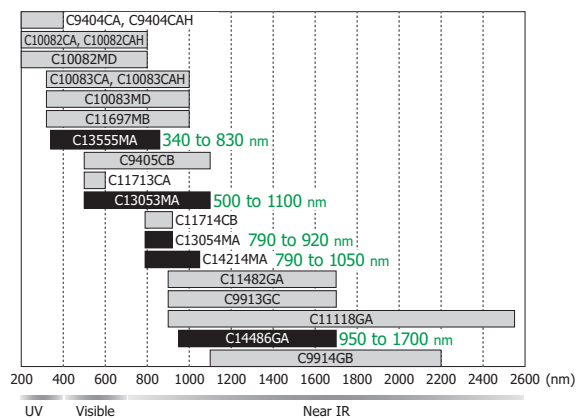

KACCB0387EB



### Features



- Compact, thin case
- High-sensitivity CMOS image sensor built in (high sensitivity equivalent to that of a CCD)
- Trigger compatible (software trigger, external trigger)\*1
- High throughput using quartz transmission grating
- External power supply not necessary (USB bus powered)
- Installable in equipment
- Stores wavelength conversion factor\*2 in internal memory

### Applications

- [ C13555MA ]
  - Visible light source inspection
  - Color measurement
- [ C13053MA ]
  - Sugar content and acidity detection of foods
  - Film thickness gauge
- [ C13054MA, C14214MA ]
  - Raman spectroscopy
- [ C14486GA ]
  - Sugar content of foods, moisture measurement



## Specifications of C13555MA, C13053MA and C14486GA (Ta=25 °C)

Parameter	C13555MA	C13053MA	NEW C14486GA	Unit
Photo				-
Type	High sensitivity		For near IR	-
Spectral response range	340 to 830	500 to 1100	950 to 1700	nm
Spectral resolution (FWHM)*3	2.3 typ., 3.0 max.	2.5 typ., 3.5 max.	5.0 typ., 7.0 max.	nm
Wavelength reproducibility*4	-0.2 to +0.2	-0.4 to +0.4	-0.4 to +0.4	mm
Wavelength temperature dependence	-0.04 to +0.04		-0.05 to +0.05	nm/°C
Spectral stray light*3	-33 max.*5		-33 max.*5	dB
A/D conversion	16			bit
Integration time	11 to 100000		1 to 100000	μs
Interface	USB 2.0			-
USB bus power current consumption	250 max.			mA
Driving external power supply	Not needed			V
Dimensions (W × D × H)	80 × 60 × 12			mm
Weight	88			g
Image sensor	High-sensitivity CMOS linear image sensor		InGaAs linear image sensor	-
Number of pixels	512		256	pixels
Slit (H × V)*6	25 × 250			μm
NA*7	0.22			-
Connector for optical fiber	SMA905D			-
Operating temperature*8	+5 to +50			°C
Storage temperature*8	-20 to +70			°C
Trigger compatible*1	Software trigger External trigger			-

## With I/O connector C13555MA-10, C13053MA-10

The C13555MA-10 and C13053MA-10 are spectrometer heads with an I/O connector for integration into devices. They have the same optical system and image sensor as the C13555MA or C13053MA. Video signals can be captured by applying drive signals.



C13555MA-10

## Block diagram (C13053MA-10)

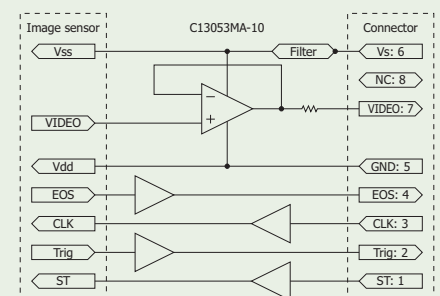

KACCC0903EA

\*1: External trigger coaxial cable is sold separately. For details on the trigger function, see P.31.

\*2: A conversion factor for converting image sensor pixel numbers into wavelengths. A calculation factor for converting the A/D converted count into a value proportional to the input light level is not provided.

\*3: When the slit in the table is used. The spectral resolution depends on the slit.

\*4: Measured under constant light input and other conditions



\*5: The ratio of the count measured when an 800 nm light is input to the count measured when that wavelength  $\pm 40$  nm light is input

\*6: Input slit aperture size

\*7: Numeric aperture (solid angle)



\*8: No dew condensation

## Specifications of C13054MA and C14214MA (Ta=25 °C)

Parameter	C13054MA	<b>NEW</b> C14214MA	Unit
Photo			-
Type	For Raman spectroscopy <b>High resolution</b>		-
Spectral response range	790 to 920	790 to 1050	nm
Spectral resolution (FWHM)*1	0.4 typ., 0.7 max.	0.4 typ., 0.6 max.	nm
Wavelength reproducibility*2	-0.2 to +0.2		nm
Wavelength temperature dependence	-0.02 to +0.02		nm/°C
Spectral stray light*1	-33 max.*3		dB
A/D conversion	16		bit
Integration time	11 to 100000		μs
Interface	USB 2.0		-
USB bus power current consumption	250 max.		mA
Driving external power supply	Not needed		V
Dimensions (W × D × H)	80 × 60 × 12	100 × 60 × 12	mm
Weight	88	95	g
Image sensor	High-sensitivity CMOS linear image sensor		-
Number of pixels	512	2048	pixels
Slit (H × V)*4	10 × 400		μm
NA*5	0.11		-
Connector for optical fiber	SMA905D		-
Operating temperature*6	+5 to +50		°C
Storage temperature*6	-20 to +70		°C
Trigger compatible*7	Software trigger External trigger		-

## C13054MA and C11714CB comparison

The spectral response range of the C13054MA and C11714CB (P15) are the same. Select the appropriate one according to your application.

Type no.	Photo	Spectral response range	Spectral resolution typ.	Features
C13054MA		790 to 920 nm	0.4 nm	Compact, thin
C11714CB			0.3 nm	High sensitivity in the near infrared region

## Spectral response (typical example)

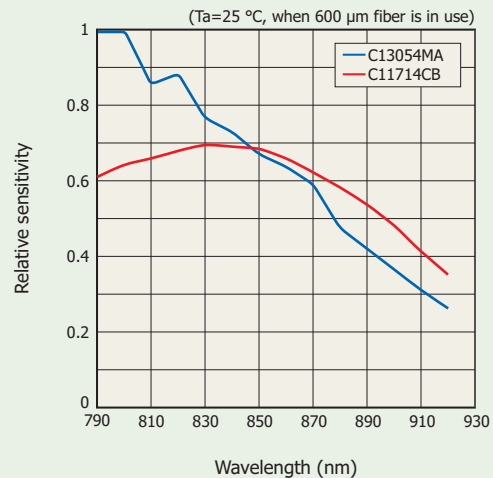

KACCB0399EA

\*1: When the slit in the table is used. The spectral resolution depends on the slit. \*2: Measured under constant light input and other conditions \*3: The ratio of the count measured when an 860 nm light is input to the count measured when that wavelength ±10 nm light is input \*4: Input slit aperture size \*5: Numeric aperture (solid angle) \*6: No dew condensation \*7: External trigger coaxial cable is sold separately. For details on the trigger function, see P31.

# RC series

## Compact, low price type

C11007MA, C11008MA

C11009MA, C11010MA

These are spectrometers with reflective grating and CMOS linear image sensor integrated into a compact form. USB output spectrometer modules (C11007MA, C11008MA) equipped with a driver circuit and spectrometer heads (C11009MA, C11010MA) for installation in equipment are available.

### Spectral response (RC/MS series, micro-spectrometers)

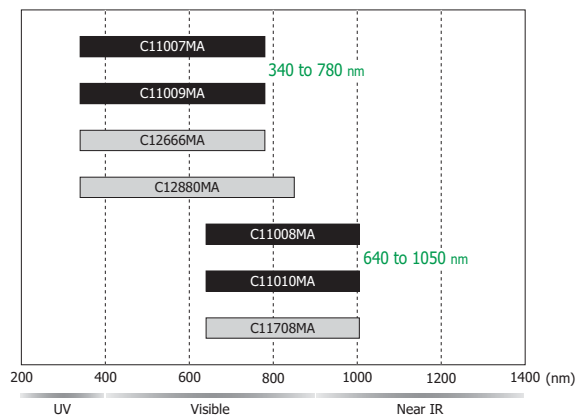

KACCB0389EA

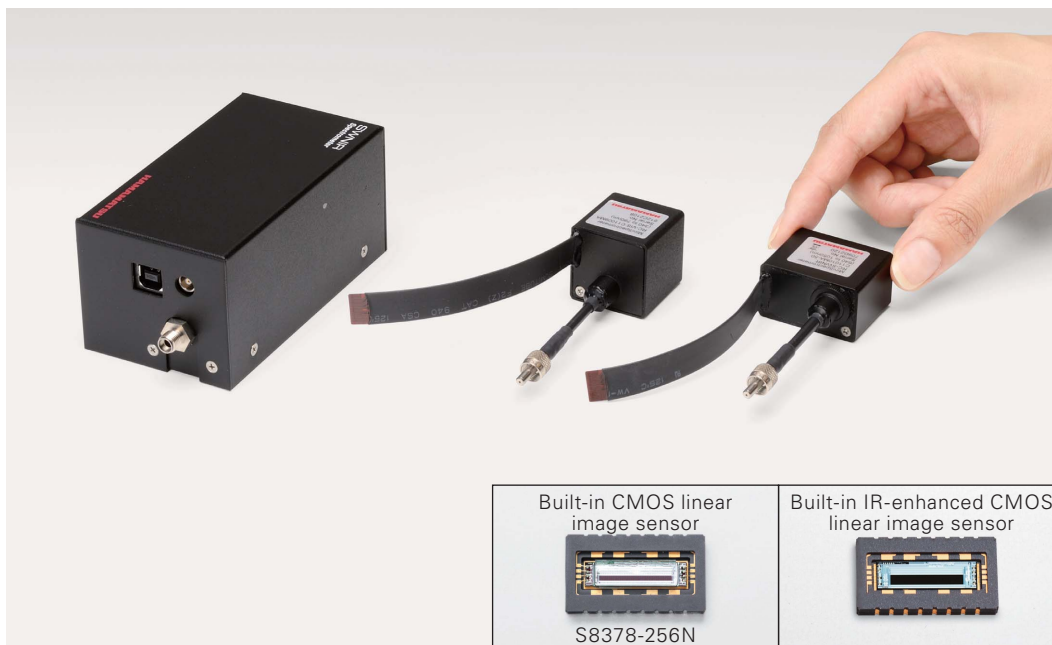

### Features

#### [ C11007MA, C11008MA (spectrometer modules) ]

- Integrated spectrometer head and driver circuit
- Spectroscopic measurement possible on a PC
- External power supply not necessary: Uses USB bus power
- A/D conversion: 16-bit
- Stores wavelength conversion factor\*8 in internal memory

#### [ C11009MA, C11010MA (spectrometer heads) ]

- For installation in devices
- Optical system and image sensor housed in a compact case
- Low cost
- Wavelength conversion factor\*8 is listed on final inspection sheet.

### Applications

#### [ C11007MA, C11009MA ]

- Installation into measuring devices
- Chemical measurement
- Visible light source inspection
- Color measurement

#### [ C11008MA, C11010MA ]

- Installation into measuring devices
- Chemical measurement
- Sugar content measurement of fruits
- Various industrial measurements

\*8: A factor for converting image sensor pixel numbers into wavelengths. A calculation factor for converting the A/D converted count into a value proportional to the input light level is not provided.

## Specifications (Ta=25 °C)

Parameter	C11007MA	C11009MA	C11008MA	C11010MA	Unit
Photo					-
Type	Spectrometer module	Spectrometer head	Spectrometer module	Spectrometer head	-
Spectral response range	340 to 780		640 to 1050 <span style="color:red">High near IR sensitivity</span>		nm
Spectral resolution (FWHM)*1	9 max.		8 max.		nm
Wavelength reproducibility*2	-0.5 to +0.5				nm
Wavelength temperature dependence	-0.05 to +0.05				nm/°C
Spectral stray light*1 *3	-30 max.				dB
A/D conversion	16	-	16	-	bit
Integration time	5 to 10000	-	5 to 10000	-	ms
Interface	USB 1.1	-	USB 1.1	-	-
USB bus power current consumption	150 max.	-	150 max.	-	mA
External driving power supply	Not needed	-	Not needed	-	-
Dimensions (W × D × H)	55 × 100 × 48	28 × 28 × 28	55 × 100 × 48	35 × 28 × 20	mm
Weight	180	52	168	45	g
Built-in spectrometer head	C11009MA	-	C11010MA	-	-
Image sensor	CMOS linear image sensor (S8378-256N)		IR-enhanced CMOS linear image sensor		-
Number of pixels	256				pixels
Slit*4 (H × V)	70 × 550		70 × 2500		μm
NA*5	0.22				-
Fiber core diameter	600				μm
Connector for optical fiber	SMA905D				-
Operating temperature*6	+5 to +40				°C
Storage temperature*6	-20 to +70				°C
Trigger compatible	-				-

## Electrical connection with external circuit (C11009MA, C11010MA)

The flexible board extending from the spectrometer head is used to electrically connect with external circuits.

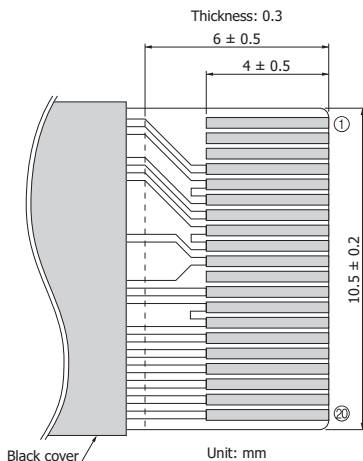

KACCC0261EB

No.	Symbol	I/O	Description	No.	Symbol	I/O	Description
①	NC		No connection	⑪	NC		No connection
②	NC		No connection	⑫	Gain	I	Image sensor: gain setting
③	NC		No connection	⑬	A.GND	-	Analog GND
④	EOS	O	Sensor scan end signal	⑭	A.GND	-	Analog GND
⑤	A.GND	-	Analog GND	⑮	ST	I	Sensor scan start signal
⑥	A.GND	-	Analog GND	⑯	CLK	I	Sensor scan sync signal
⑦	Video	O	Video output signal	⑰	SDA	O	Temperature sensor output signal
⑧	A.GND	-	Analog GND	⑱	SCL	I	Temperature sensor drive signal
⑨	A.GND	-	Analog GND	⑲	D.GND	-	Temperature sensor digital GND
⑩	+5 V	I	Image sensor power supply: +5 V	⑳	VCC	I	Temperature sensor: +3.3 V

Note:

· ④ to ⑩ and ⑫ to ⑯ are connected to the image sensor.

For the drive conditions, refer to the S8377/S8378 series CMOS linear image sensor datasheet.

· ⑰ to ⑳ are connected to the temperature sensor (DS1775R by DALLAS) built into the spectrometer.

\*1: When the slit in the table is used. The spectral resolution depends on the slit. \*2: Measured under constant light input and other conditions  
 \*3: The ratio of the count measured when a 550 nm (C11007MA, C11009MA) or 850 nm (C11008MA, C11010MA) light is input to the count measured when that wavelength  $\pm 40$  nm light is input \*4: Input slit aperture size \*5: Numeric aperture (solid angle) \*6: No dew condensation

# Micro-spectrometers, MS series

## Ultra-compact spectrometer heads

Wide dynamic range

C12666MA

High sensitivity

C12880MA

For near IR

C11708MA

Based on an advanced MOEMS technology, a thumb-sized ultra-compact spectrometer heads have been achieved by combining an input-slit-integrated CMOS image sensor and grating formed through nanoimprint on a convex lens. As they employ an easily mountable package, you can use them as though they were sensors.

## Spectral response (RC/MS series, micro-spectrometers)

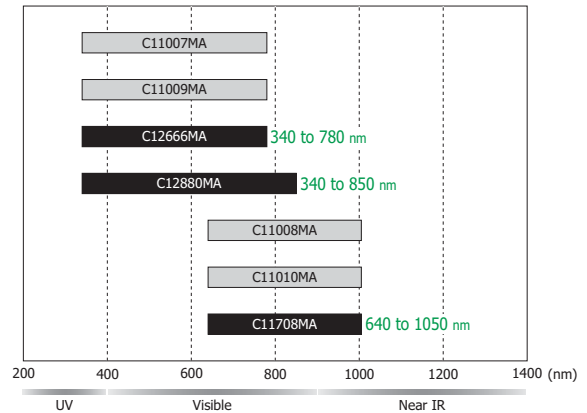

KACCB0388EA



### Features

- Ultra-compact
- Hermetically sealed package:
  - High reliability under humid conditions (C12666MA, C12880MA)
- For installation into mobile measuring devices
- Wavelength conversion factor\*7 is listed on final inspection sheet.

### Applications

#### [ C12666MA, C12880MA ]



- Color monitoring on printers, printing presses, etc.
- Tester for lights, LEDs, etc.
- Display color adjustment
- Water quality control monitors and other environment measuring instruments
- Measuring instruments that use portable devices, such as smartphones and tablets

#### [ C11708MA ]

- Sugar content measurement of fruits
- Taste evaluation of grains
- Composition analysis

\*7: A factor for converting image sensor pixel numbers to wavelengths. A calculation factor for converting the A/D converted count into a value proportional to the input light level is not provided.

## Specifications (Ta=25 °C)

Parameter	Micro-spectrometer		MS series	Unit
	C12666MA	C12880MA	C11708MA	
Photo				-
Type	Spectrometer head <b>Wide dynamic range</b>	Spectrometer head <b>High sensitivity</b>	Spectrometer head <b>For near IR</b>	-
Spectral response range	340 to 780	340 to 850	640 to 1050	nm
Spectral resolution (FWHM)*1	15 max.		20 max.	nm
Wavelength reproducibility*2	-0.5 to +0.5			nm
Wavelength temperature dependence	-0.1 to +0.1		-0.05 to +0.05	nm/°C
Spectral stray light*1 *3	-25 max.			dB
Dimensions (W × D × H)	20.1 × 12.5 × 10.1		27.6 × 16.8 × 13	mm
Weight	5		9	g
Image sensor	CMOS linear image sensor	High-sensitivity CMOS linear image sensor	CMOS linear image sensor	-
Number of pixels	256	288	256	pixels
Slit (H × V)*4	50 × 750	50 × 500	75 × 750	μm
NA*5	0.22			-
Operating temperature*6	+5 to +50			°C
Storage temperature*6	-20 to +70			°C
Trigger compatible	-			-
Evaluation circuit (sold separately)	C14465-10	C13016	C14465	-

Note: We also provide the C12880MA-10, which is identical to the C12880MA except that it has an SMA connector.

## Measurable incident light level

CMOS image sensor built into the C12666MA has a large saturation charge, and that built into the C12880MA has a large charge-to-voltage conversion gain.

To perform high S/N measurement, the C12666MA is recommended when the incident light level is high and the C12880MA when the level is low.

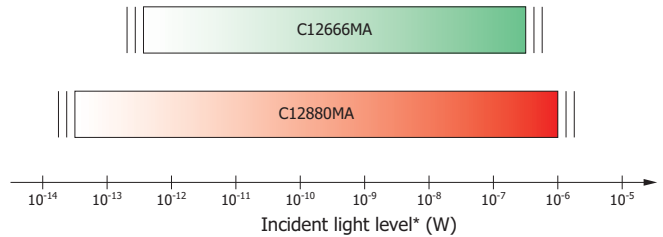

\* Input spot diameter: 800 μm (λ=550 nm)  
 The measurable light level is calculated from the settable integration time.  
 The settable integration time is different between the C12666MA and C12880MA.  
 The S/N during measurement is not taken into account.

KACCB0354EA

## Micro-spectrometer evaluation circuit

A circuit board designed to simply evaluate the characteristics of the micro-spectrometer is available (sold separately). The micro-spectrometer is connected to a PC with a USB cable A9160 (AB type, sold separately). Evaluation software is included.



C14465-10 and C12666MA

## Evaluation software display example

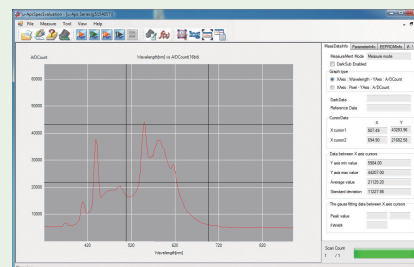

## Connection example

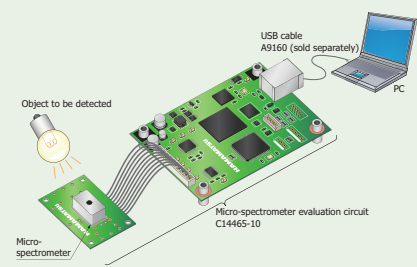

KACCC0799EB

\*1: When the slit in the table is used. The spectral resolution depends on the slit. \*2: Measured under constant light input and other conditions. \*3: The ratio of the count measured when the following wavelength light is input to the count measured when that wavelength ±40 nm light is input, C12666MA: 560 nm, C12880MA: 655 nm, C11708MA: 850 nm. \*4: Input slit aperture size. \*5: Numeric aperture (solid angle). \*6: No dew condensation.



# Technical note

## 1 Structure

Wavelength dispersive spectrometers are broadly grouped into monochromator and polychromator types. Monochromators use a grating as the wavelength dispersing element for separating the incident light into a monochromatic spectrum. Polychromators utilize the principle of monochromators and are designed to allow simultaneous detection of multiple spectra. Mini-spectrometers fall under the polychromator type. In monochromators, an exit slit is usually formed on the focal plane of a focus lens, while in polychromators an array type detector (image sensor) is placed along the focal plane of the focus mirror/lens. To make mini-spectrometers compact, the polychromators use a collimating lens and focus mirror/lens with a shorter focal distance compared to monochromators.

[Figure 1] Optical component layout (TG series)

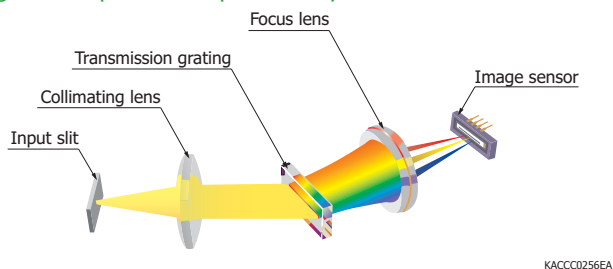

The function of each component is explained below.

### » Input slit

The input slit is the opening for receiving the light to be measured. The input slit restricts the spatial spread of the measurement light that enters the mini-spectrometer, and the slit image of the incident light is focused on the image

sensor. The narrower the input slit, the more the spectral resolution is improved, but the throughput becomes lower. An optical fiber is connected to the mini-spectrometer input slit.

### » Collimating mirror/lens

The light passing through the input slit spreads at a certain angle. The collimating mirror/lens collimate this slit transmitted light and guide it onto the grating. At this point, an aperture (aperture mask) is used along with the collimating mirror/lens to limit the NA (numerical aperture) of the light flux entering the mini-spectrometer.

### » Grating

The grating separates the incident light guided through the collimating mirror/lens into each wavelength and lets the light at each wavelength pass through or be reflected at a different diffraction angle. There are two types of gratings for mini-spectrometers: transmission type and reflection type.

### » Focus mirror/lens

The focus mirror/lens focuses the light from the grating onto an image sensor in the order of wavelength.

### » Image sensor

The image sensor converts the spectrum of light focused according to each wavelength by the focus mirror/lens into electrical signals, and then outputs them. Cooled mini-spectrometers incorporate a thermoelectrically cooled image sensor to reduce image sensor noise.

## Micro-spectrometer configuration

Besides a CMOS image sensor chip integrated with an optical slit by etching technology, the micro-spectrometer employs a reflective concave blazed grating formed by nanoimprint. The glass used in the light path of the previous products is not used, making it extremely compact.



### Structure diagram

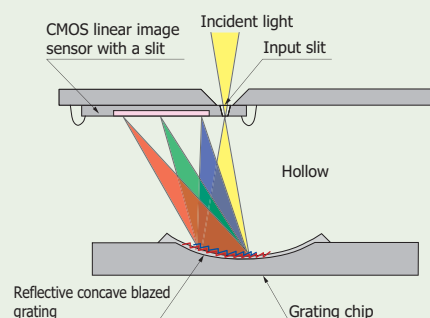

### CMOS linear image sensor with a slit [Incident light side (back of chip)]

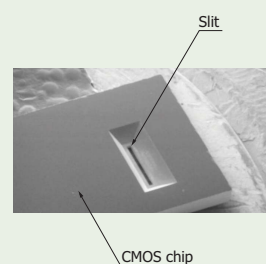

KACCC0757EB

## 2 Characteristics

### » Spectral resolution

#### (1) Definition of spectral resolution

The spectral resolution of mini-spectrometers is defined based on the full width at half maximum (FWHM). FWHM is the spectral width at 50% of the peak power value as shown in Figure 2. Figure 3 shows examples of spectral resolution measured with different types of mini-spectrometers.

[Figure 2] Definition of full width at half maximum

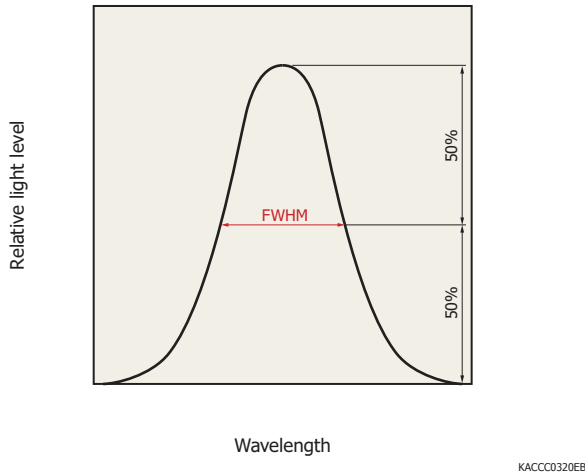

#### (2) Changing the spectral resolution

The spectral resolution of mini-spectrometers varies depending on the slit width and NA. In the C10082CA, for example, the slit width is 70  $\mu\text{m}$  and the NA is 0.22. Figure 4 shows typical examples of spectral resolution when the NA is changed to 0.11 and the slit width is narrowed. This proves that the spectral resolution can be improved down to about 1 nm by changing conditions.

However, narrowing the slit width and reducing the NA will limit the light incident on the mini-spectrometer. The light level reaching the image sensor will therefore decrease.

For example, when comparing the C10082CA with the C10082CAH, the slit width of the C10082CA is 70  $\mu\text{m}$  while that of the C10082CAH is 10  $\mu\text{m}$ , which is 1/7 of the C10082CA. This means that the light level passing through the slit of the C10082CAH is 1/7 of the C10082CA. On the other hand, due to the difference in the NA in the spectrometers, the light level that reaches the C10082CAH image sensor is approximately 1/4th the level that reaches the C10082CA image sensor. However, because the spectral resolution of the C10082CAH is approximately 1/4th that of the C10082CA, the A/D count of the C10082CAH is approximately 4 times that of the C10082CA. As a result, when the light level entering the optical fiber is the same, the A/D count of the C10082CAH is approximately 1/7th that of the C10082CA.

[Figure 4] Spectral resolution vs. wavelength (typical example when slit width and NA for C10082CA were changed)

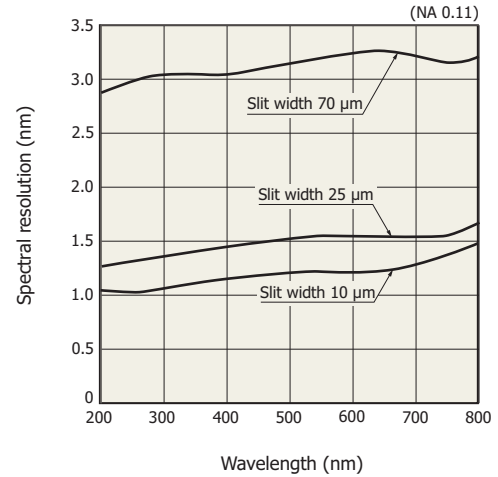

[Figure 3] Spectral resolution vs. wavelength (typical example)

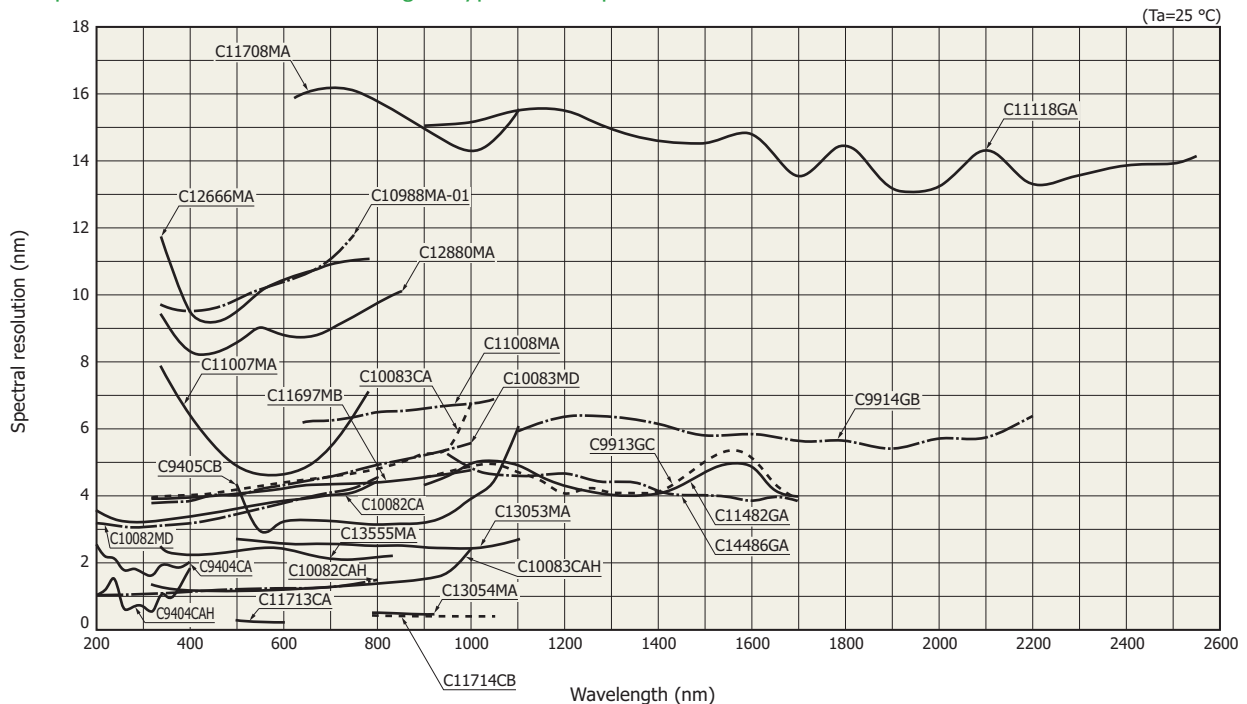

Figures 5 and 6 show the spectral resolution of the C10082CA/C10083CA series, and Table 1 shows the NA and slit width.

[Figure 5] Spectral resolution vs. wavelength (C10082CA series)

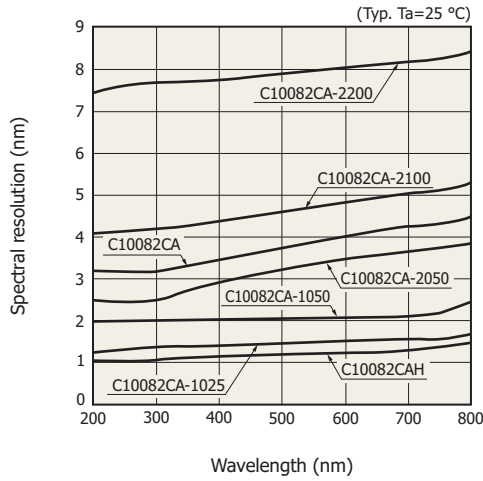

KACCB0194EA

[Figure 6] Spectral resolution vs. wavelength (C10083CA series)

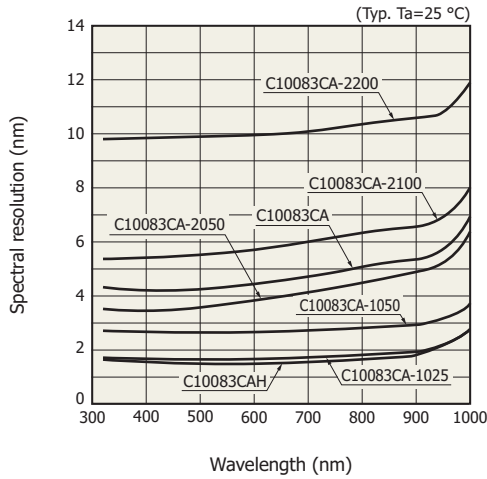

KACCB0195EA

[Figure 7] Output characteristics (C10082CA series)

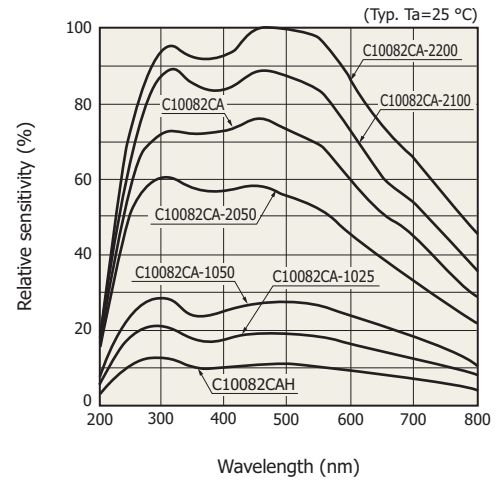

KACCB0196EA

[Figure 8] Output characteristics (C10083CA series)

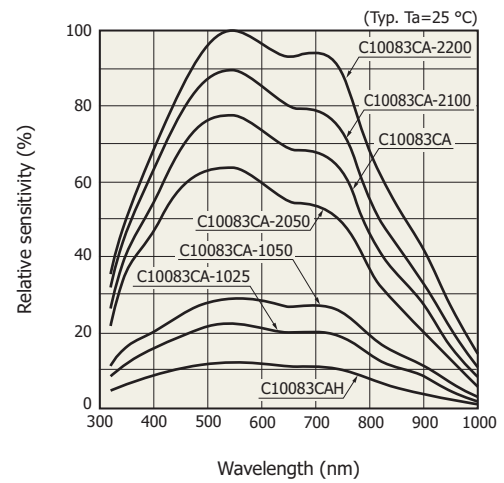

KACCB0197EA

[Table 1] C10082CA/C10083CA series NA and slit width

Type no.		NA	Slit width
Spectral response range 200 to 800 nm	Spectral response range 320 to 1000 nm		
C10082CA-2200	C10083CA-2200	0.22	200 μm
C10082CA-2100	C10083CA-2100		100 μm
C10082CA	C10083CA		70 μm
C10082CA-2050	C10083CA-2050		50 μm
C10082CA-1050	C10083CA-1050	0.11	50 μm
C10082CA-1025	C10083CA-1025		25 μm
C10082CAH	C10083CAH		10 μm

(3) Spectral detection width assigned per pixel of image sensor  
 This section describes the spectral detection width that is assigned per pixel of the image sensor mounted in a mini-spectrometer. The spectral detection width is different from spectral resolution. The approximate spectral detection width assigned per pixel is obtained by dividing the spectral response range by the number of pixels of the image sensor.

· Example: C10082CA (spectral response range: 200 to 800 nm, 2048 pixels)

$$\text{Spectral detection width assigned per pixel} = (800 - 200)/2048 \approx 0.3 \text{ nm} \dots (1)$$

The detection wavelength of any given pixel is calculated from equation (2) using the wavelength conversion factor that is written in the EEPROM in the mini-spectrometer. This allows obtaining the wavelength assigned to any pixel.

$$\text{Detection wavelength of any given pixel [nm]} = a_0 + a_1\text{pix} + a_2\text{pix}^2 + a_3\text{pix}^3 + a_4\text{pix}^4 + a_5\text{pix}^5 \dots (2)$$

a0 to a5: wavelength conversion factor  
 pix: any pixel number of image sensor (1 to the last pixel)

Hamamatsu mini-spectrometers are designed so that the spectral width assigned per pixel in the image sensor is small relative to the spectral resolution. When a line spectrum is measured with a mini-spectrometer, the output is divided into multiple pixels as shown in Figure 9. The center wavelength of the line spectrum can be found by approximating this measurement result with a Gaussian curve.

[Figure 9] Finding the center wavelength of line spectrum by approximation

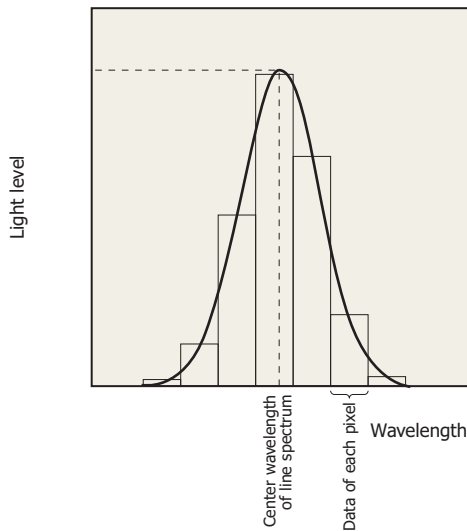

KACCC0335EB

## » Stray light

Stray light is generated as a result of extraneous light entering the detector (image sensor), which should not be measured. The following factors can generate stray light.

- Fluctuating background light
- Imperfections in the grating
- Reflection from lens, detector window, and detector photosensitive area

## ⚙ Definition of stray light

There are two methods to define stray light: one method uses a long-pass filter and the other method uses reference light in a narrow spectral range (light output from a monochromator or line spectra emitted from a spectral line lamp, etc.).

The long-pass filter method uses light obtained by making white light pass through a long-pass filter for particular wavelengths. In this case, the stray light is defined as the ratio of transmittance in the “wavelength transmitting” region to transmittance in the “wavelength blocking” region. The stray light level (SL) in this case is defined by equation (3). (See Figure 10 for the definitions of Tl and Th.)

$$SL = 10 \times \log(Tl/Th) \dots \dots \dots (3)$$

This definition allows measuring the effects of stray light over a wide spectral range and so is used as an evaluation method suitable for actual applications such as fluorescence measurement. However, be aware that the intensity profile of white light used as reference light will affect Tl and Th values.

[Figure 10] Definitions of Tl and Th

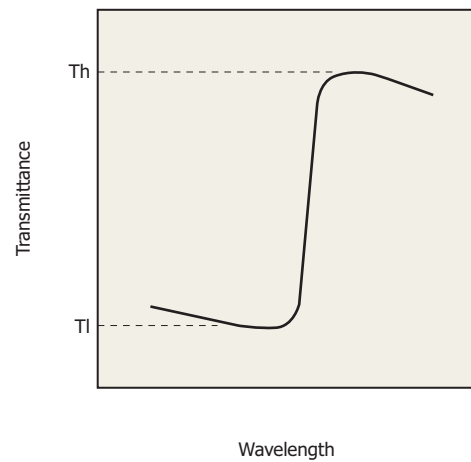

KACCC0255EA

In the other method using reference light in a narrow spectral range, the stray light level is defined by equation (4).

$$SL = 10 \times \log(I_M/I_R) \dots \dots \dots (4)$$

I<sub>M</sub>: unnecessary light level that was output at wavelengths deviating from the reference light spectrum  
 I<sub>R</sub>: reference light level

This definition is not affected by the reference light because the measurement conditions are simple.

In both definition methods, the stray light conditions will differ depending on the wavelength to be detected. The stray light should therefore be measured at multiple wavelengths.

[Figure 11] Examples of stray light measurement using line spectra (C11482GA)

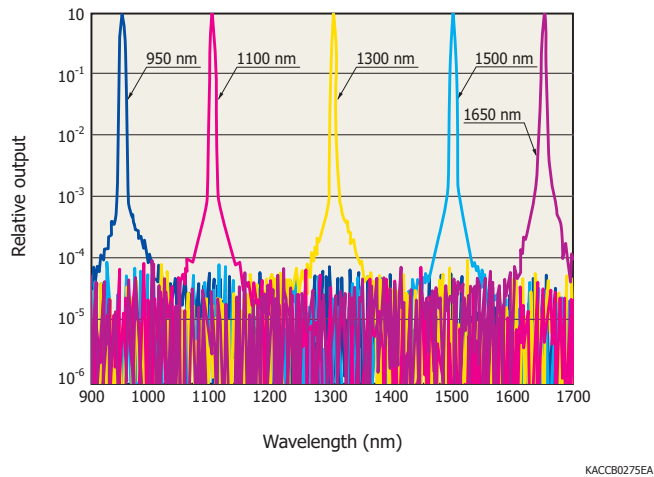

» Sensitivity

The output charge of an image sensor mounted in mini-spectrometers is expressed by equation (5).

$$Q(\lambda) = k(\lambda) \times P(\lambda) \times T_{exp} \dots\dots\dots (5)$$

- Q(λ): image sensor output charge [C]
- k(λ): conversion factor for converting the light level entering a mini-spectrometer into image sensor output charge (equals the product of optical system efficiency, diffraction efficiency of grating, and image sensor sensitivity)
- P(λ): incident light level [W] at each wavelength incident on mini-spectrometer
- T<sub>exp</sub>: integration time [s]

The output charge of an image sensor is converted into a voltage by the charge-to-voltage converter circuit and then converted into a digital value by the A/D converter. This is finally derived from the mini-spectrometer as an output value. The output value of a mini-spectrometer is expressed by equation (6).

$$I(\lambda) = \varepsilon \times Q(\lambda) = \varepsilon \times k(\lambda) \times P(\lambda) \times T_{exp} \dots\dots\dots (6)$$

- I(λ): mini-spectrometer output value [counts]
- ε: conversion factor for converting image sensor output charge into a mini-spectrometer output value (equals the product of the charge-to-voltage converter circuit constant and the A/D converter resolution)

Meanwhile, the sensitivity of a mini-spectrometer is expressed by equation (7).

$$E(\lambda) = I(\lambda)/(P(\lambda) T_{exp}) \dots\dots\dots (7)$$

- E(λ): sensitivity of mini-spectrometer [counts/(W·s)]

When equation (6) is substituted into equation (7), we obtain equation (8).

$$E(\lambda) = \varepsilon \times k(\lambda) \dots\dots\dots (8)$$

[Table 2] Wavelength dependence of parameters that determine conversion factor

Parameter determining conversion factor	Wavelength dependence
Optical system efficiency	Yes
Diffraction efficiency of grating	Yes
Image sensor sensitivity	Yes
Charge-to-voltage converter circuit constant	No
A/D converter resolution	No

[Figure 12] Spectral response (relative value)

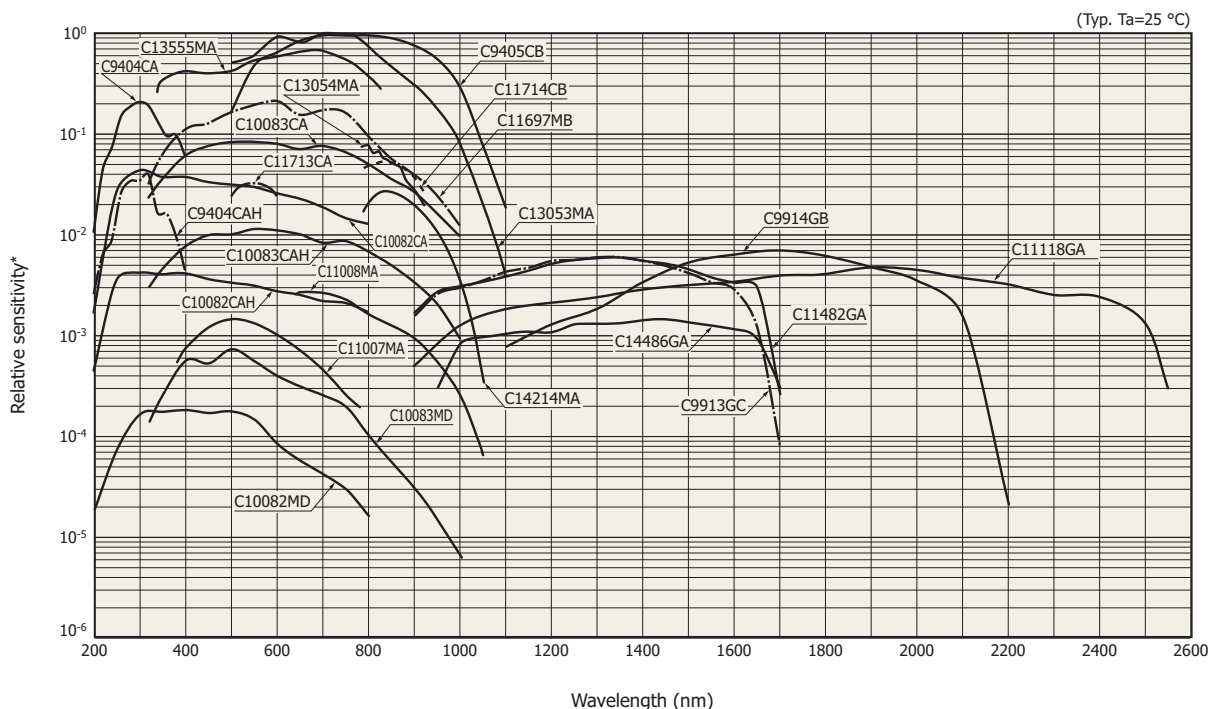

\* A/D count when constant light level enters optical fiber (Fiber core diameter: 600 μm, assuming no attenuation in optical fiber)

### 3 Operation mode

#### » Free-run operation (normal operation mode)

When light enters an image sensor, an electrical charge is generated in each pixel of the image sensor according to the incident light level. This charge accumulates in each pixel during the integration time and is cleared to zero when read out. This means that the charge must be read out before starting integration of newly generated charges. In mini-spectrometers, this cycle of “charge integration → charge readout (A/D conversion) → digital data hold” repeats in a cycle. Digital data is constantly updated with data obtained in the latest integration time. When a data request is received from the PC, the mini-spectrometer sends the latest data at that point to the PC. Figure 13 shows the free-run operation.

[Figure 13] Free-run operation

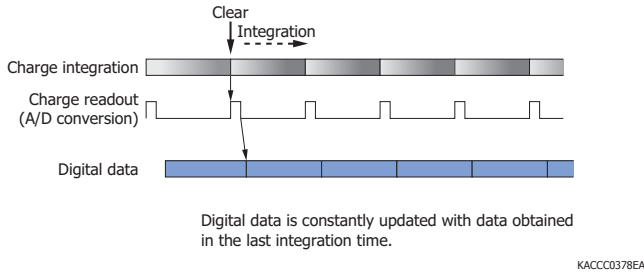

#### » Operation mode when trigger is input [TM/TG series (USB 1.1 compatible)]\*1

The TM/TG series mini-spectrometers (USB 1.1 compatible) that support external trigger operation can acquire data based on external trigger signal input. The external trigger function works with DLL, but does not function on the supplied evaluation software. Therefore, when using an external trigger function, the user software must be configured to support that function. Use the A10670 coaxial cable for external trigger (sold separately) to connect the mini-spectrometer to a device that outputs digital signals at 0 V to 5 V levels.

[Figure 14] Mini-spectrometer connectors (C10082CA)

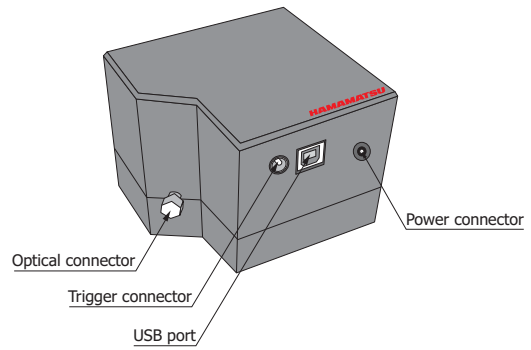

KACCC0377EB

Operation modes using external trigger input are described below.

##### (1) Data hold by external trigger input

This operation mode differs from free-run operation in that data to be held is controlled by trigger input. The mini-spectrometer internally holds digital data accumulated during the integration time that begins just after the trigger input edge (rising or falling edge can be specified). This data being held is then reset when it is read out from the PC. If the next trigger is input while the data is still being held, then that data is updated to new digital data. For example, when a mini-spectrometer is used to detect light emitted from a DC mode light source with a shutter installed, then data accumulated in a predetermined integration time can be held by supplying the mini-spectrometer with a trigger input for shutter open operation. Measurements can be made under high repeatability conditions by setting a shutter open period that is sufficiently longer than the integration time.

[Figure 15] Data hold responding to external trigger input

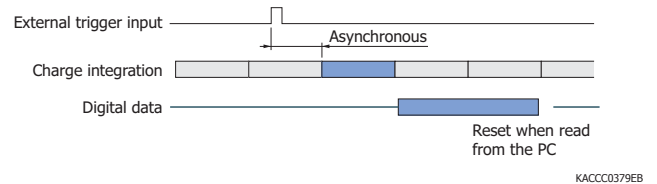

##### (2) Data labeling during external trigger input

This operation mode attaches a label to digital data during the gate period for external trigger input. A label is attached to digital data during trigger input (high level or low level can be specified). When the digital data is read out from the PC, the label information can be obtained at the same time.

[Table 3] Operation mode compatibility table

Operation mode	C9913GC, C9914GB C11007MA, C11008MA	C9404CA, C9404CAH, C9405CB C10082CA, C10082CAH, C10082MD C10083CA, C10083CAH, C10083MD C11713CA, C11714CB Refer to *1 (P.31).	C11118GA, C11697MB C11482GA, C13555MA C13053MA, C13054MA C14486GA, C14214MA Refer to *2 (P.32).
Free-run operation	○	○	○
External trigger operation	×	○	○
Software trigger operation	×	×	○



When acquiring data under different measurement conditions, this mode is suitable for identifying which measurement condition applies to the measurement data. For example, suppose measurements are made under condition A and condition B. Condition A uses no trigger input to make measurements, so there is no labeling. In contrast, condition B uses a trigger input, so a label is attached to the acquired data. Labeling the acquired data in this way during trigger input makes it possible to distinguish between acquired data measurement conditions.

[Figure 16] Data labeling at external trigger input

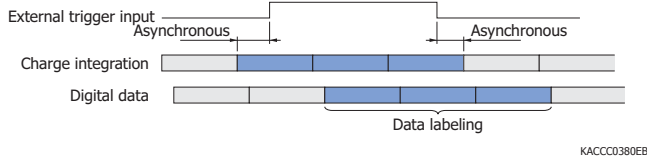

» Operation mode when trigger is input [TM/TG/TF series (USB 2.0 compatible)]\*2

The TM/TG/TF series mini-spectrometers (USB 2.0 compatible) can acquire data based on trigger signal input from a PC. It is also possible to acquire and output data using an external trigger signal received through the trigger connector. The operation mode can be selected from the evaluation software supplied with the mini-spectrometer.

(1) Asynchronous data measurement at software trigger input

The first piece of digital data that is converted after a software trigger is applied from the PC is acquired.

[Figure 17] Asynchronous data measurement at software trigger input

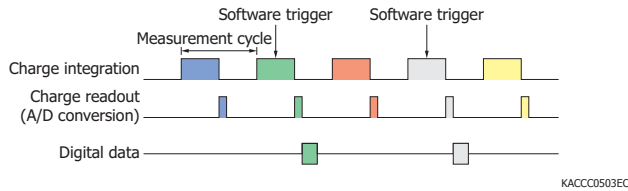

(2) Synchronous data measurement at software trigger input

Data integration starts when a software trigger is applied from the PC.

[Figure 18] Synchronous data measurement at software trigger input

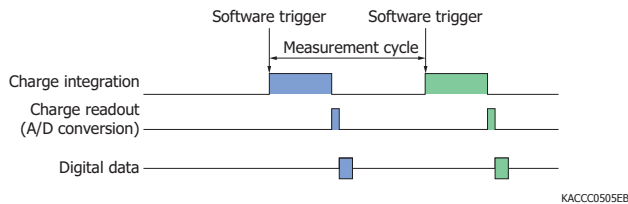

(3) Asynchronous data measurement at external trigger input

The first piece of digital data that is converted after an external trigger edge (rising or falling edge can be specified) is applied to the trigger connector is acquired.

[Figure 19] Asynchronous data measurement at external trigger input

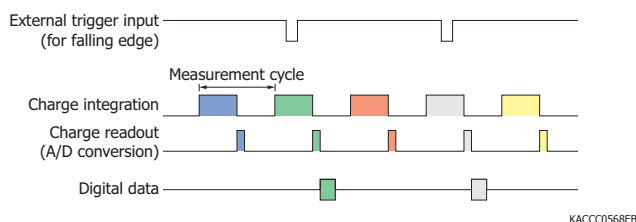

(4) Synchronous data measurement at external trigger input

Data integration starts when an external trigger edge (rising or falling edge can be specified) is applied to the trigger connector, and then the digital data is acquired.

[Figure 20] Synchronous data measurement at external trigger input

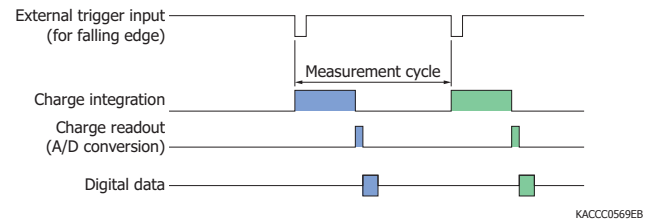

(5) Asynchronous data measurement at external trigger input level

Digital data is acquired when an external trigger (high level or low level can be specified) is applied to the trigger connector.

[Figure 21] Asynchronous data measurement at external trigger input level

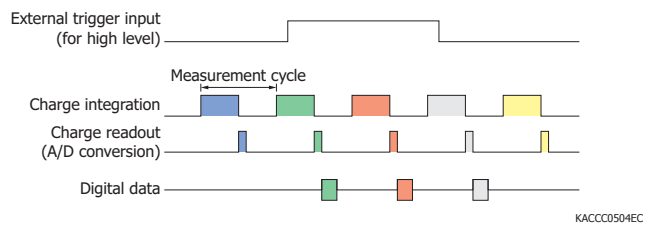

(6) Synchronous data measurement at external trigger input level

Data integration starts when a trigger (high level or low level can be specified) is applied to the trigger connector, and then the digital data is acquired.

[Figure 22] Synchronous data measurement at external trigger input level

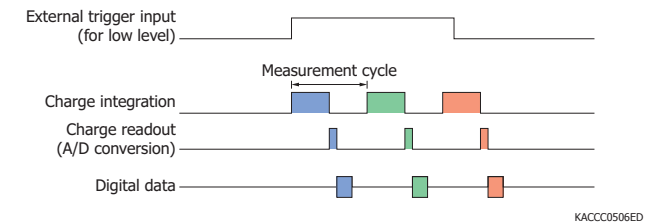

In any of the above modes (1) to (6), if the trigger input cycle is shorter than the measurement cycle of the mini-spectrometer, the input trigger is ignored.

(7) External trigger signal output

The start timing (pulse width: 10 μs) of integration can be output from the trigger connector (trigger output edge: rising or falling edge can be specified).

[Figure 23] External trigger signal output

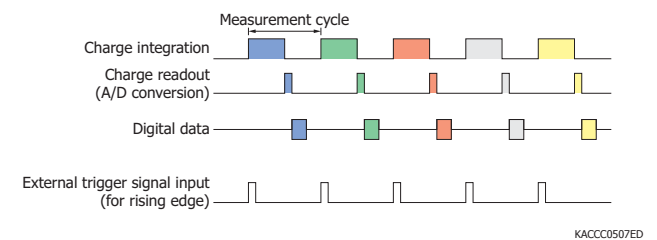

Most Hamamatsu mini-spectrometers come with an evaluation software package.

### » Evaluation software functions

By installing the evaluation software into a PC, you can perform the following basic operations.

- Acquire and save measured data
- Set measurement conditions
- Module information acquisition (wavelength conversion factor\*1, mini-spectrometer type, etc.)
- Display graphs
- Arithmetic functions

Pixel number to wavelength conversion/calculation in comparison with reference data (transmittance, reflectance)/dark subtraction/Gaussian approximation (peak position and count, FWHM)

\*1: A factor for converting the pixel numbers of the image sensor to wavelengths. However, a factor for converting the count values after A/D conversion into incident light levels is not available.

### » Evaluation software types

The following five types of evaluation software are available. Each type can only be used for specific mini-spectrometers.

- For the TM/TG series (USB 1.1 interface)
- For the TM/TG/TF series (USB 2.0 interface)

- For the RC series
- For evaluation circuit C14465 series
- For evaluation circuit C13016

[Figure 24] Display examples of evaluation software

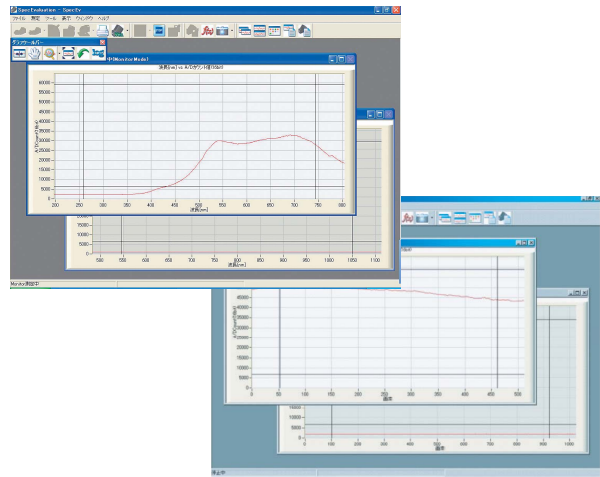

The evaluation software has measurement modes including Monitor, Measure, Dark, and Reference. Table 5 shows the features of each mode. Data measured in Measure mode, Dark mode\*2, and Reference mode\*2 can be saved in csv format (loadable into Microsoft® Excel®).

Table 6 shows the arithmetic functions of the evaluation software, and Table 7 shows limitations on setting parameters during measurement.

\*2: The C11118GA, C11697MB, C11482GA, C13053MA, C13054MA, C13555MA, C14486GA, C14214MA, C14465 series, and C13016 do not have Dark or Reference mode. The Measure mode serves as the Dark and Reference modes.

[Table 4] Evaluation software compatibility table

Parameter		Mini-spectrometer TM/TG/TF series		Mini-spectrometer RC series	Evaluation circuit C14465 series	Evaluation circuit C13016
		USB 1.1	USB 2.0			
Applicable mini-spectrometers		C10082CA C10082CAH C10082MD C10083CA C10083CAH C10083MD C9404CA C9404CAH C9405CB C11713CA C11714CB C9913GC C9914GB	C11482GA C11118GA C11697MB C13555MA C13053MA C13054MA C14486GA C14214MA	C11007MA C11008MA	C11708MA C12666MA	C12880MA
Compatible OS	Windows® 7 Professional (32-bit, 64-bit)	○	○	○	○	○
	Windows 8 Professional (32-bit, 64-bit)	○	○	○	○	○
	Windows 10 Professional (32-bit, 64-bit)	○	○	○	○	-
Disclosure of DLL function specifications		○	○	○	○	○
Connecting and driving multiple mini-spectrometers from a single PC (evaluation software)		○	○	-	-	-
Multiple data transfer function		-	○	-	-	-
Compatible development environment	Visual C++®/CLI	○	○	○	○	○
	Visual Basic®	○	○	○	○	○
	LabVIEW	-	-	-	-	-
Source code disclosure		-	-	-	-	-

**[Table 5] Measurement modes of evaluation software**

Mode	Overview	Features
Monitor mode	Measurement mode not intended to save acquired data	Graphically displays “pixel no. vs. A/D output value” in real time
		Graphically displays “wavelength vs. A/D output value” in real time
		Graphically displays time-series data at a selected wavelength* <sup>3</sup>
		Cannot save measurement data
		Performs dark subtraction
		Displays reference data
Measure mode	Measurement mode intended to save acquired data	Graphically displays “pixel no. vs. A/D output value” in real time
		Graphically displays “wavelength vs. A/D output value” in real time
		Graphically displays time-series data at a selected wavelength* <sup>3</sup>
		Saves measurement data
		Performs dark subtraction
		Displays reference data
Dark mode* <sup>4</sup>	Measurement mode for acquiring dark data (used to perform dark subtraction)	Graphically displays “pixel no. vs. A/D output value” in real time
		Graphically displays “wavelength vs. A/D output value” in real time
		Saves measurement data
Reference mode* <sup>4</sup>	Measurement mode for acquiring reference data	Graphically displays “pixel no. vs. A/D output value” in real time
		Graphically displays “wavelength vs. A/D output value” in real time
		Saves measurement data
Trigger mode* <sup>3</sup>	Measurement mode for acquiring data by trigger signal	Software trigger, asynchronous measurement
		Software trigger, synchronous measurement
		External trigger, asynchronous edge
		External trigger, asynchronous level
		External trigger, synchronous edge
Continuous measurement mode* <sup>3</sup>	Continuous data acquisition by batch data transfer	Graphically displays “pixel no. vs. A/D output value” at completion of data transfer
		Graphically displays “wavelength vs. A/D output value” at completion of data transfer
		Saves measurement data

\*3: Only supported by the C11118GA, C11697MB, C11482GA, C13053MA, C13054MA, C13555MA, C14486GA, and C14214MA

\*4: The C11118GA, C11697MB, C11482GA, C13053MA, C13054MA, C13555MA, C14486GA, C14214MA, C14465 series, and C13016 do not have Dark or Reference mode. The Measure mode serves as the Dark and Reference modes.

**[Table 6] Arithmetic functions of evaluation software**

Function	Features
Dark subtraction	Displays measurement data after dark data subtraction
Reference data measurement/display	Measures reference data and displays it graphically
Gaussian fitting	Fits a specified range of data using a Gaussian function

[Table 7] Limitations on setting parameters

Parameter	Limitation	
Integration time	1 $\mu$ s to 100 ms	C14486GA
	11 $\mu$ s to 100 ms* <sup>1</sup>	C13555MA, C13053MA, C13054MA, C14214MA, C13016
	30 $\mu$ s to 100 ms* <sup>1</sup>	C11697MB
	6 $\mu$ s to 40 ms* <sup>1</sup>	C11118GA
	5 ms to 1 s	C9914GB
	5 ms to 10 s	C10082MD, C10083MD, C9913GC, C11007MA, C11008MA, C14465, C14465-01
	6 $\mu$ s to 10 s* <sup>1</sup>	C11482GA
	10 ms to 10 s	C10082CA, C10082CAH, C10083CA, C10083CAH, C9404CA, C9404CAH, C9405CB, C11713CA, C11714CB
Gain	High/Low	C10082MD, C10083MD, C11482GA, C9913GC, C9914GB, C11007MA, C11008MA, C11118GA
Scan count	The number of times continuous measurement can be performed in continuous measurement mode depends on the memory size and operation status of the PC (not limited during Monitor mode).	

\*1: Specified in 1  $\mu$ s steps

## » Interface

Mini-spectrometers come with DLLs. By using this DLL, users can create Windows applications for controlling mini-spectrometers in a software development environment such as Visual C++/CLI and Visual Basic\*<sup>2</sup> \*<sup>3</sup>. Because Windows application software cannot directly access a USB host controller, the necessary functions should be called from the DLL to allow the software to access the USB host controller via the USB driver and to control the mini-spectrometer (see Figure 25). The DLL provides functions for opening/closing USB ports, setting measurement conditions, getting data and module information, and so on.

\*2: Operation has been verified using Visual Studio® 2010, 2013, 2015 Visual C++/CLI and Visual Studio 2010, 2013, 2015 Visual Basic on .NET Framework 3.5, 4.0, 4.5 (Windows 7, 8, 10).

\*3: The C11351 comes with a DLL, but the specifications of functions are not disclosed.

Note: Microsoft, Windows, Excel, Visual C++/CLI, Visual Basic, and Visual Studio are either registered trademarks or trademarks of Microsoft Corporation in the United States and/or other countries.

[Figure 25] Software configuration example

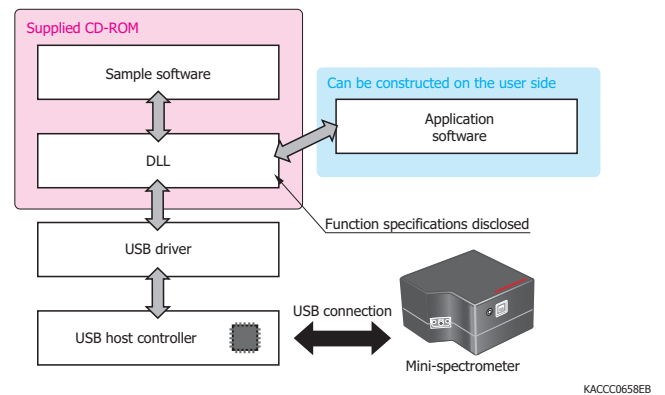

## 5 Application examples

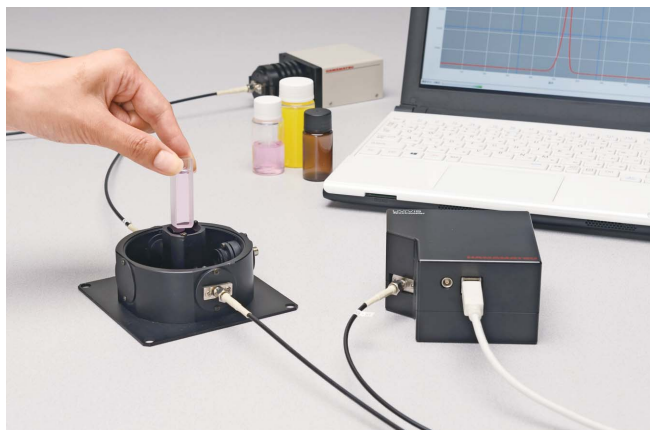

[Figure 26] Connection example (measurement of liquid absorbance)

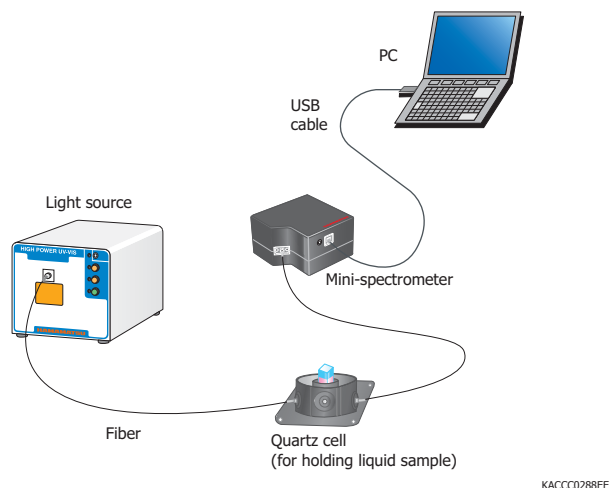

KACCC0288EE

### » Fluorescence measurement

This is an example of measuring fluorescence from a 1000 ppm quinine solution (buffer solution: dilute sulfuric acid).

[Figure 27] Fluorescence measurement example (C10083CA)

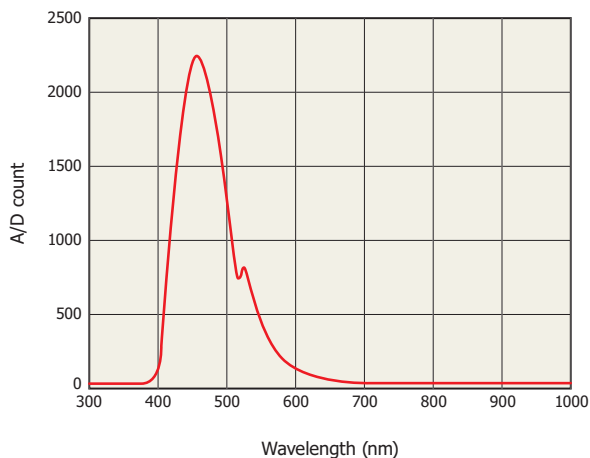

KACCB0145EA

### » LED emission measurement

#### (1) Visible LED

[Figure 28] Visible LED measurement example (C10082MD)

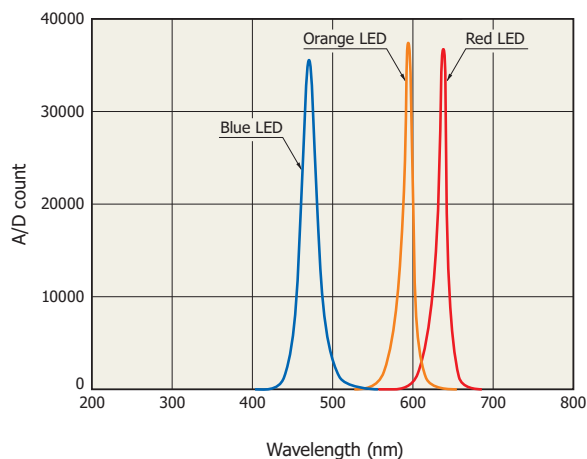

KACCB0126EA

#### (2) White LED and 3-color LED

Figure 29 is an example of measuring emissions from a white LED and 3-color LED. White LED light contains wavelength components of various colors as well as blue, and appears white because those colors are mixed together.

[Figure 29] White LED and 3-color LED measurement example (C11007MA)

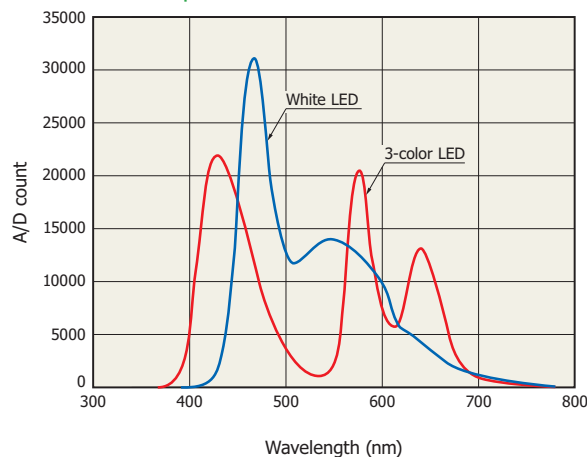

KACCB0100EA

### » Transmittance measurement

[Figure 30] Transmittance (1 mm thick optical window) measurement example (C11482GA)

#### (a) Measurement value

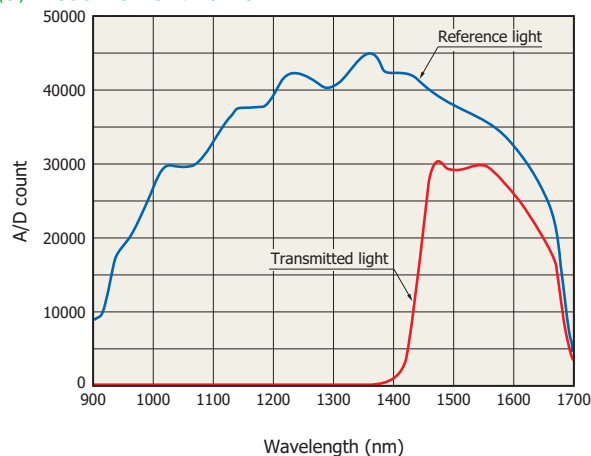

KACCB0276EA

### (b) Calculation result

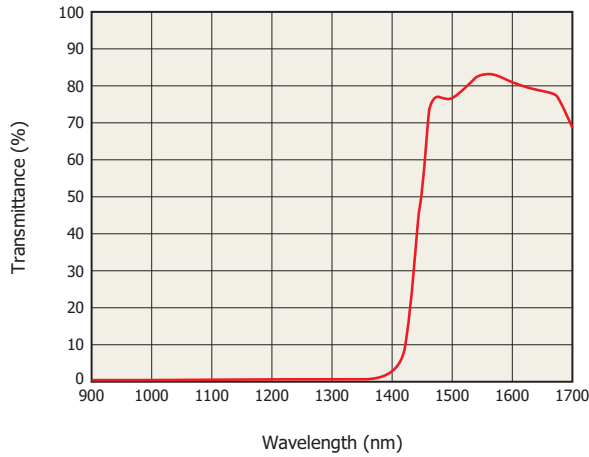

KACCB0277EA

### » Line spectrum measurement

[Figure 31] Measurement example of low-pressure mercury lamp's line spectra (C11714CB)

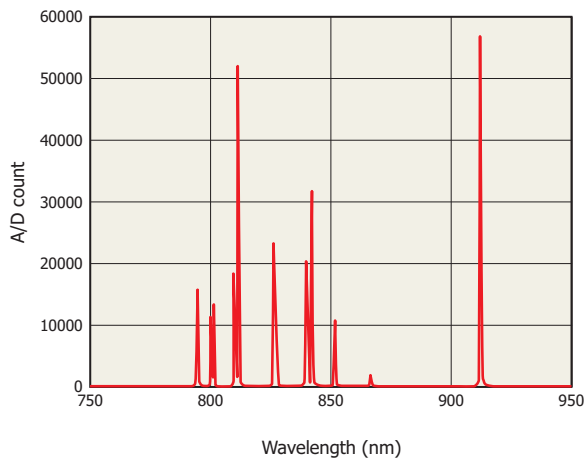

KACCB0280EA

### » Reflectance measurement

[Figure 32] Measurement example of spectral reflectance of reflecting mirror (C9405CB)

#### (a) Measurement value

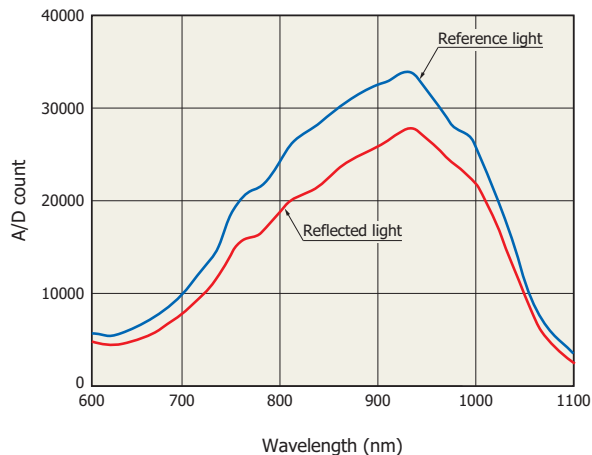

KACCB0278EA

### (b) Calculation result

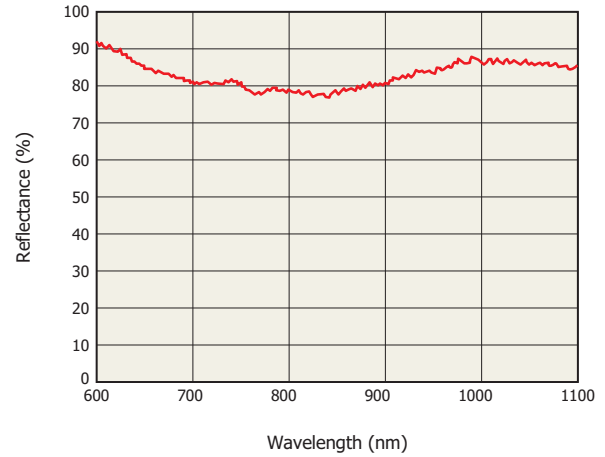

KACCB0279EA

### » Film thickness measurement

Here we show an example that measures the film thickness of 10  $\mu\text{m}$  thick food wrap (polyvinylidene chloride). In film thickness measurement utilizing white light interferometry, a rippling interference spectrum is obtained due to reflections between the front and back surfaces of the film. The film thickness can then be determined by calculation from the spectral peak count, wavelength range, refractive index of film, and the angle of incident light.

[Figure 33] Film thickness measurement example (C11482GA)

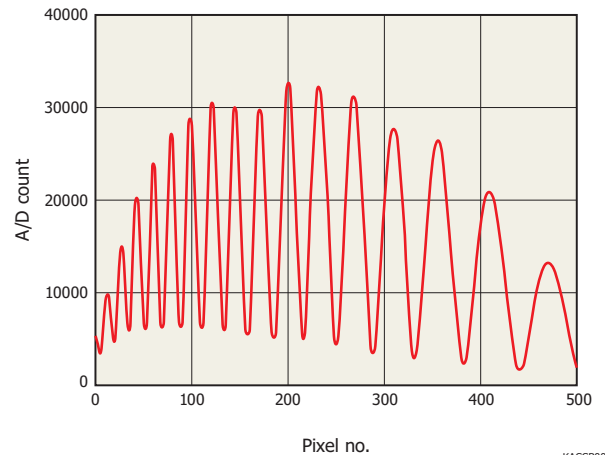

KACCB0095EB

### » Raman spectroscopy

[Figure 34] Raman light measurement example of naphthalin sample (C11714CB)

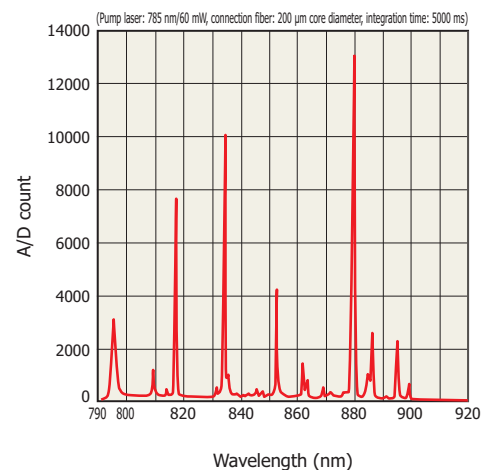

KACCB0229EA



# Related products

## Input optical fibers A9762-01, A9763-01

As accessories for the mini-spectrometers, UV-visible optical fiber (UV resistant) and visible-NIR optical fiber with a core diameter of 600  $\mu\text{m}$  are available (sold separately). Note that the fiber is incorporated in the C11009MA and C11010MA of the mini-spectrometer RC series.

Type no.	Product name	Applicable mini-spectrometers	Core diameter ( $\mu\text{m}$ )	Specifications
A9762-01	UV-visible optical fiber (UV light resistant)	C10082CA, C10082CAH, C10083CA, C10083CAH, C10082MD, C10083MD, C9404CA, C9404CAH, C11007MA, C11697MB, C13555MA	600	NA=0.22, 1.5 m in length, with SMA905D connector on each end
A9763-01	Visible-NIR optical fiber	C9405CB, C11482GA, C9913GC, C9914GB, C11008MA, C11118GA, C11713CA, C11714CB, C13053MA, C13054MA, C14214MA, C14486GA		

## External trigger coaxial cables A10670, A12763

Type no.	Applicable mini-spectrometers
A10670	C9404CA, C9404CAH, C9405CB, C10082CA, C10082CAH, C10082MD, C10083CA, C10083CAH, C10083MD, C11713CA, C11714CB, C11118GA, C11697MB, C11482GA
A12768	C13555MA, C13053MA, C13054MA, C14486GA, C14214MA

## Dimensional outlines (unit: mm)

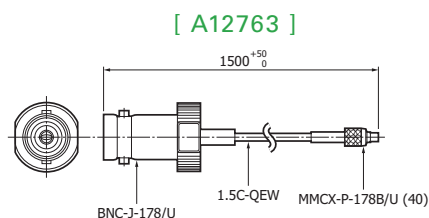
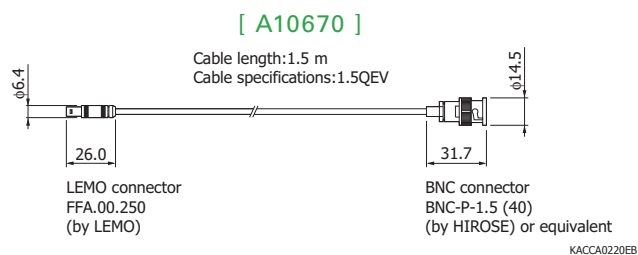

## Spectroscopic modules C12710, C13560

These are compact, lightweight Raman spectroscopy analysis modules. A compact spectrometer, excitation light source, wavelength filter, and other optical elements are integrated into a single unit. The modules can be used for onsite screening tests and other applications that use Raman spectroscopy. In addition, using the surface-enhanced Raman spectroscopy (SERS) substrate makes high-sensitivity Raman spectroscopic analysis possible. The C12710, a high-resolution portable type, and the C13560, a palm-sized lightweight type, are available.



C12710



C13560

## Compact UV to visible (UV-VIS) S2D2 fiber light source (UV enhanced type) L12515

The L12515 is a UV to visible fiber light source employing a compact deuterium lamp (S2D2 lamp). It outputs stable light ranging from 200 nm to 1600 nm from the light guide (sold separately).

Compact, easy-to-carry, and easy-to-use were key features considered in the design. It can be applied to various portable equipment. It can be applied to various portable equipment.

### Features

- Compact: 74 × 40 × 110 mm
- High stability: Fluctuation 0.004 % p-p typ. ( $2 \times 10^{-5}$  A.U. or equivalent)
- Improvement in SN ratio through the enhancement of output in the UV region



Note: The light guide is sold separately.

### Spectral distribution (typical example)

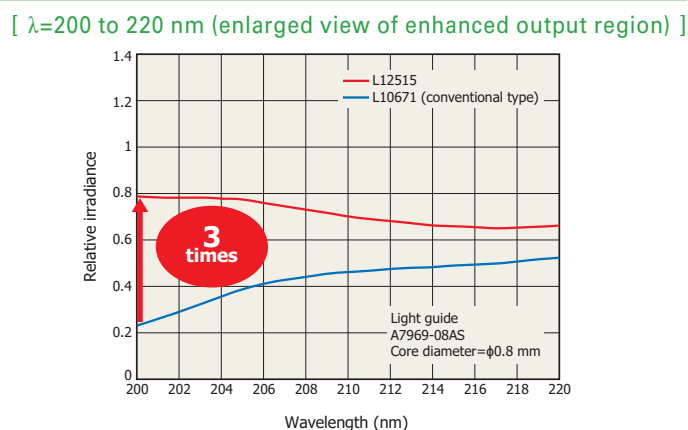
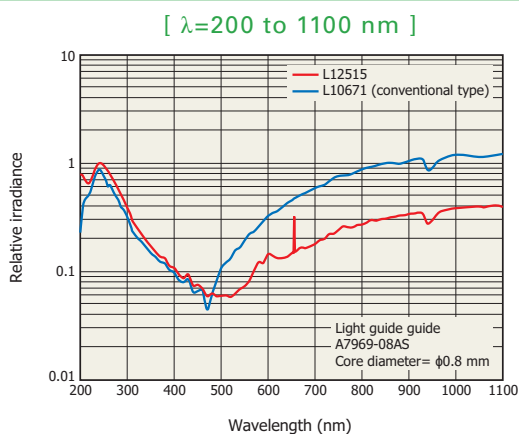

## Compact 2 W xenon flash lamp module L13651 series

The L13651 series is a 2 W xenon flash lamp module that has achieved miniaturization by integrating the illumination operating circuit. This product is not only an ideal light source for compact analysis equipment used in environmental analysis, sampling tests, and the like but also can be incorporated in portable analysis equipment used in high accuracy environment monitoring, POCT, and the like with operation on a 5 V mobile battery, whose development is expected in the future.

### Features

- Compact: 37 × 42 × 42 mm
- Operates on 5 V mobile battery
- Long life:  $1 \times 10^9$  flash
- Repetition rate: 1250 Hz max.
- Broad spectrum: UV region to middle IR region



Note: The light guide is sold separately.

### Spectral irradiance (typical example)

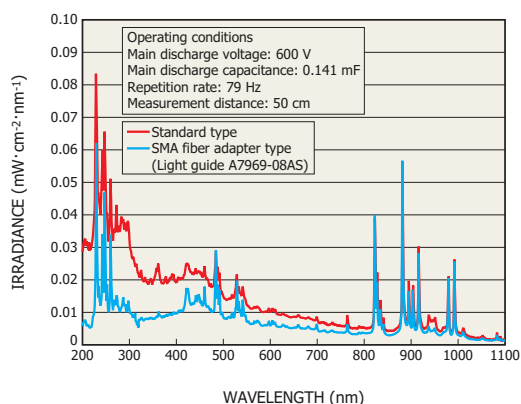





Архангельск (8182)63-90-72  
Астана (7172)727-132  
Астрахань (8512)99-46-04  
Барнаул (3852)73-04-60  
Белгород (4722)40-23-64  
Брянск (4832)59-03-52  
Владивосток (423)249-28-31  
Волгоград (844)278-03-48  
Вологда (8172)26-41-59  
Воронеж (473)204-51-73  
Екатеринбург (343)384-55-89  
Иваново (4932)77-34-06

Ижевск (3412)26-03-58  
Иркутск (395)279-98-46  
Казань (843)206-01-48  
Калининград (4012)72-03-81  
Калуга (4842)92-23-67  
Кемерово (3842)65-04-62  
Киров (8332)68-02-04  
Краснодар (861)203-40-90  
Красноярск (391)204-63-61  
Курск (4712)77-13-04  
Липецк (4742)52-20-81  
Киргизия (996)312-96-26-47

Магнитогорск (3519)55-03-13  
Москва (495)268-04-70  
Мурманск (8152)59-64-93  
Набережные Челны (8552)20-53-41  
Нижний Новгород (831)429-08-12  
Новокузнецк (3843)20-46-81  
Новосибирск (383)227-86-73  
Омск (3812)21-46-40  
Орел (4862)44-53-42  
Оренбург (3532)37-68-04  
Пенза (8412)22-31-16  
Казахстан (772)734-952-31

Пермь (342)205-81-47  
Ростов-на-Дону (863)308-18-15  
Рязань (4912)46-61-64  
Самара (846)206-03-16  
Санкт-Петербург (812)309-46-40  
Саратов (845)249-38-78  
Севастополь (8692)22-31-93  
Симферополь (3652)67-13-56  
Соленск (4812)29-41-54  
Сочи (862)225-72-31  
Ставрополь (8652)20-65-13  
Таджикистан (992)427-82-92-69

Сургут (3462)77-98-35  
Тверь (4822)63-31-35  
Томск (3822)98-41-53  
Тула (4872)74-02-29  
Тюмень (3452)66-21-18  
Ульяновск (8422)24-23-59  
Уфа (347)229-48-12  
Хабаровск (4212)92-98-04  
Челябинск (351)202-03-61  
Череповец (8202)49-02-64  
Ярославль (4852)69-52-93

<https://hamamatsu.nt-rt.ru/> || [hsm@nt-rt.ru](mailto:hsm@nt-rt.ru)

## Disclaimer

- Products manufactured by Hamamatsu Photonics K.K. (hereafter "Hamamatsu") are intended for use in general-use electronic devices (such as measurement equipment, office equipment, information communications equipment, household appliances, etc.). Unless an exception to the following is stated in the documentation of a specific product, Hamamatsu products are not to be used for special applications which demand extremely high reliability or safety (such as equipment for nuclear power control, aerospace equipment, medical equipment and transportation equipment that directly affect human life, or disaster prevention or safety equipment).
- Hamamatsu products should not be used in excess of their absolute maximum ratings. Attention must be paid to all documented precautions.
- Hamamatsu continually makes efforts to improve the quality and reliability of its products; however these efforts cannot ensure 100% compliance with the manufacturing specifications. Sufficient safety design (such as redundant safety, fire preventative, and malfunction preventative features) are to be implemented in the development of equipment manufactured with the Hamamatsu product so that personal injury, fire, or damage to public property or welfare does not occur in the unlikely event of a malfunction of the Hamamatsu product. A dangerous condition could be created if sufficient consideration is not given to safety design that addresses potential problems, especially in the design of equipment where the failure or malfunction of the Hamamatsu product within the equipment could result in bodily harm, life-threatening injury, or serious property damage during the use of the equipment. With such types of equipment, Hamamatsu shall not be responsible for the use of its products within the equipment in any way for not obtaining our written consent such as specification sheets beforehand.
- Appropriate descriptions of the functions, performance, and methods of operation of the Hamamatsu product and the equipment within which the Hamamatsu product is incorporated are to be provided to end-users of the equipment. All accompanying warnings and cautionary labeling are also to be provided to the end-user.
- Warranty of the Hamamatsu product is limited to the repair or replacement of a product in which a defect is discovered within 1 year of delivery of the product and notification is made to Hamamatsu within that period, otherwise certain warranty is specified. However, even within the warranty period Hamamatsu shall not be responsible for damages caused by either natural disaster or improper use of the product (such as modification of the product or any use that contravenes the operating conditions, intended applications, operating instructions, storage method, disposal method, or any other term or condition described in our products' documents). For a complete description of the warranty associated with a particular product, please contact your regional Hamamatsu sales office.
- Exportation of some Hamamatsu products must comply with individual governmental regulations pertaining to export control. Export in contravention of governmental regulations is a crime and can result in severe monetary penalties or imprisonment. While we cannot give any legal advice as to how to comply with these regulations, we can help classify the goods in order to assist the buyer in determining what regulations apply. Please contact your regional Hamamatsu sales office for further assistance.
- In our products' documents, applications are mentioned as notable examples of how the Hamamatsu product can be used. Such mentions guarantee neither the suitability of the product for specific purposes nor the success or failure of the commercial use of the product in specific applications. Some applications may be protected by patents or other proprietary rights. Hamamatsu assumes no liability for any infringing use of our products. All warranties express or implied, including any warranty of merchantability or fitness for any particular purpose are hereby excluded.
- Product specifications are subject to change without notification due to product improvements, etc. Our products' documents have been carefully prepared to ensure the accuracy of the technical information contained herein, but in rare cases there may be errors. When using the Hamamatsu product, please be sure to request the delivery specification sheets, and confirm upon delivery that it is the most recent specifications. In addition to this document, please be sure to read any accompanying technical documentation and make note of any precautions listed in the delivery specification sheets.
- All Rights Reserved, transfer or duplication of the contents of our products' documents without the permission of Hamamatsu is prohibited.